

DOI: 10.5281/zenodo.3949662
UDC 681.586:676



SENSOR FOR AN AUTOMATIC MEASUREMENT OF MECHANICAL PROPERTIES OF RECOVERED PAPER OBJECTS

Tobias Krebs*, ORCID ID: 0000-0002-0120-4801,
Samuel Schabel, ORCID ID: 0000-0002-7207-8208

Technische Universität Darmstadt, Karolinenplatz 5, 64289 Darmstadt, Germany

*Corresponding author: Tobias Krebs, krebs@papier.tu-darmstadt.de

Received: 06. 27. 2020

Accepted: 08. 05. 2020

Abstract. Recovered paper is the most important raw material for paper industry today and paper industry is one of the forerunners of circular economy. However, despite the long history with recycling the characterization of recovered paper quality is still not solved sufficiently. Here the automatic classification of paper objects can bring significant progress. Up to now, most technical approaches use NIR sensors and visual cameras, which can only “see” the surface of the objects. This often leads to misclassifications, since, for example, many packages look like graphic papers due to their printed surface. To improve these challenging classification tasks, sensors for mechanical properties of the paper objects can make an important contribution. In this paper, an automatic sensor is presented which can measure force characteristics when penetrating paper objects with specially shaped measuring tips. These force characteristics show good correlations to the mechanical properties determined in the laboratory according to standardized methods.

Keywords: *automation, machine learning, mechanical properties, paper object classification, recovered paper, sensor technology, recovered paper quality.*

Introduction

Recovered paper is one of the most important raw materials in paper industry for the production of new paper. To make this raw material available to the paper industry, it is necessary to collect used paper products. A distinction is made between commercial sources and private households. Commercial sources often generate very homogeneous recovered paper grades due to their economic activity. Examples are office paper from companies, packaging paper from supermarkets or returned, unread newspapers and magazines. Private households generate very heterogeneous paper grades from everyday life.

The recovered paper from private households is sorted after collection in recovered paper sorting plants. The sorting process aims to split the paper into fractions suitable for different markets, such as the production of graphic paper or packaging paper. The requirements for the grades of recovered paper on the market are standardized in Europe in a European list of standard grades of paper and board for recycling [1]. The composition of

the recovered paper objects within a grade is specified as a central quality factor. It is not trivial to assess the composition of a large amount of recovered paper, e.g. within the scope of an incoming inspection in paper mills. The greatest significance is today obtained by manual analysis of a sufficiently large sample quantity in the order of magnitude of 50 to 200 kg. However, such analyses are time-consuming, labor-intensive and therefore expensive. A number of measuring systems that can analyze and evaluate recovered paper can be found in literature [2-11]. However, detailed compositions of recovered paper samples, e.g. to check the specifications of the list of the European list of standard grades of paper and board for recycling, can still only be determined by manual analysis.

Figure 1 shows the advancement of an automatic measuring system presented in [10], which was developed for the detailed determination of the composition of recovered paper samples. The principle of the measuring system is based on the separation of paper objects using a screen drum (1) and robot system (2) and subsequent sensory analysis of the isolated objects in a measuring cell (3) as well as classification by algorithms from the field of machine learning. The most common sensors used in the analysis of recovered paper include camera systems and NIR sensors, which are also used in this measuring system to determine color, shape, pattern and spectroscopic characteristics of the objects.

A major weakness of these sensors is that they can only detect properties on the top side of the object. Especially packaging with elaborately printed surfaces is therefore often recognized wrongly as graphic paper. For this reason, a sensor for determining mechanical paper properties was developed and integrated into the measuring system. It is expected that the knowledge of mechanical properties of paper objects will make a further important contribution to the correct classification of paper objects, since many packaging and graphic papers differ in their mechanical properties. In literature, only [2] contains, among other sensors, a sensor that can be used to determine the bending stiffness of recovered paper objects.

Apart from that, sensors for mechanical properties are not used in any of the measuring systems mentioned.

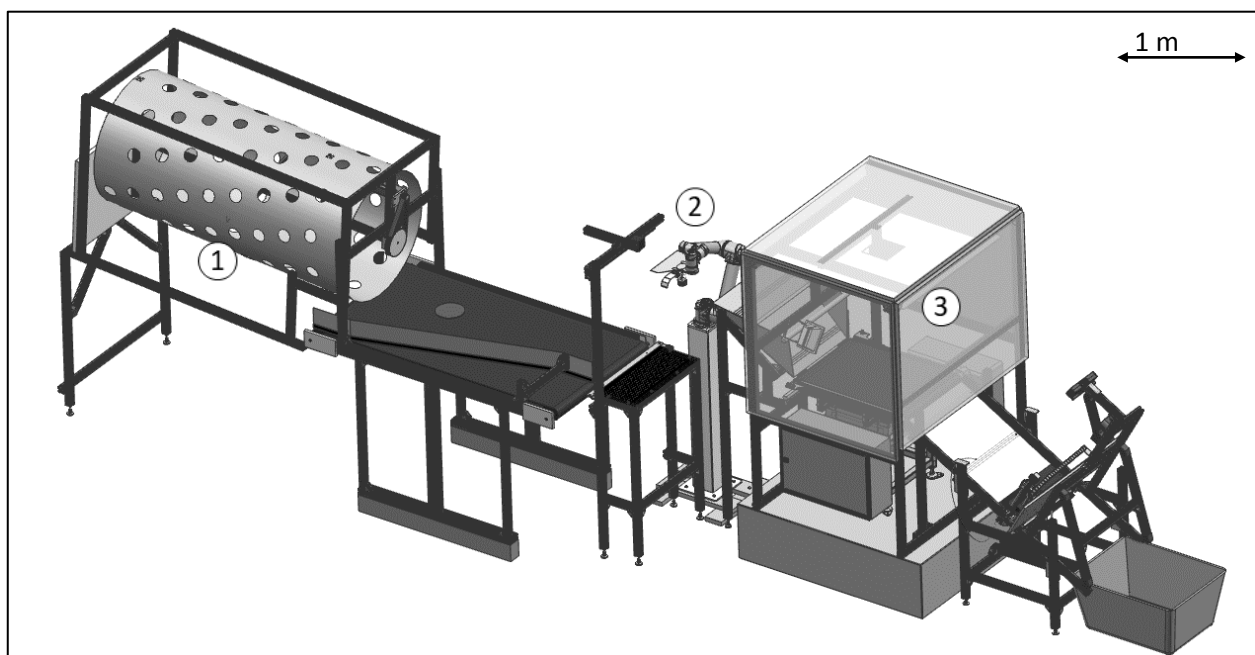

Figure 1. CAD representation of the automatic measuring system.

In the following sections, the structure of a newly developed sensor capable of automatically measuring the mechanical properties of individual paper objects will be described. Subsequently, analogies between the measurement of the sensor and established laboratory methods will be shown. This is followed by two sections describing the measurement data of the sensor and showing correlations between these measurement data and the laboratory measurement values. Finally, the most important findings are summarized.

Design of the sensor and measuring process

Paper objects have different mechanical properties among other things due to their different fiber and filler compositions, grammages and finishings. The sensor presented here takes advantage of the fact that papers offer different resistance to damage to their structure. In most cases, these resistances can be measured in the form of forces. Therefore, the sensor measures the force curve when penetrating the paper objects with specially designed measuring tips. These measuring tips are shaped in such a way that different mechanical properties are tested in different phases of the penetration. In particular, conclusions are to be drawn about the puncture resistance, bursting strength and tear strength of the examined objects. The initial situation before the measurement is shown in figure 2.

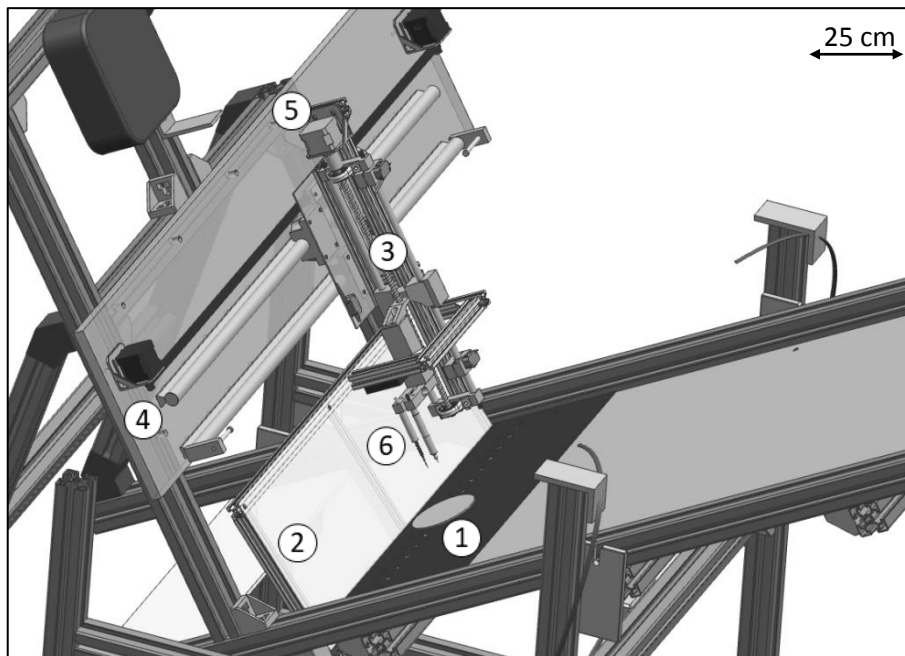

Figure 2. Tactile sensor for measuring mechanical properties of paper objects.

The object to be examined (1) slides down the inclined plane of the sensor and is stopped by an initially closed flap at the end of the plane (2). The sensor (3), which is attached to a carriage, can be moved horizontally and thus perpendicular to the sliding direction of the objects by means of a belt drive and two stepper motors along two guide rails (4). Along the direction of movement of the carriage, 18 holes are drilled in the inclined plane, which are possible measuring positions. The position of the object can be determined by means of a camera located at a fixed position above the measuring set-up. The sensor is moved perpendicular to the inclined plane by a spindle driven by a stepper motor at its upper end (5). Here again, a carriage moves along the axis of movement. This

carriage is stabilized by one guide rod on each side to prevent bending due to the application of forces. The forces that are transmitted to the two measuring tips of the sensor (6) when penetrating the object are measured with the help of load cells. After data acquisition, the flap is opened and the paper object falls into a collecting container.

The sensor is controlled by a software programmed in Matlab. The control of all mechanical components, such as the motors or the flap, as well as the data acquisition is outsourced to a microcontroller.

Analogies to laboratory test methods

The primary goal of the sensor is to extract as much information as possible about the mechanical properties of the paper objects under investigation. By appropriate selection of the design of the measuring tips, analogies to established laboratory testing methods of mechanical paper properties can be obtained. Figure 3 shows the design of the two measuring tips.

When determining the puncture resistance according to DIN 53 142, the force or energy required to puncture the object to be tested with a pyramid-shaped puncture body defined in the standard is measured. The same happens when puncturing the paper object with the first measuring tip of the sensor (1), except that the measuring tip of the newly developed sensor is equipped with a conical tip.

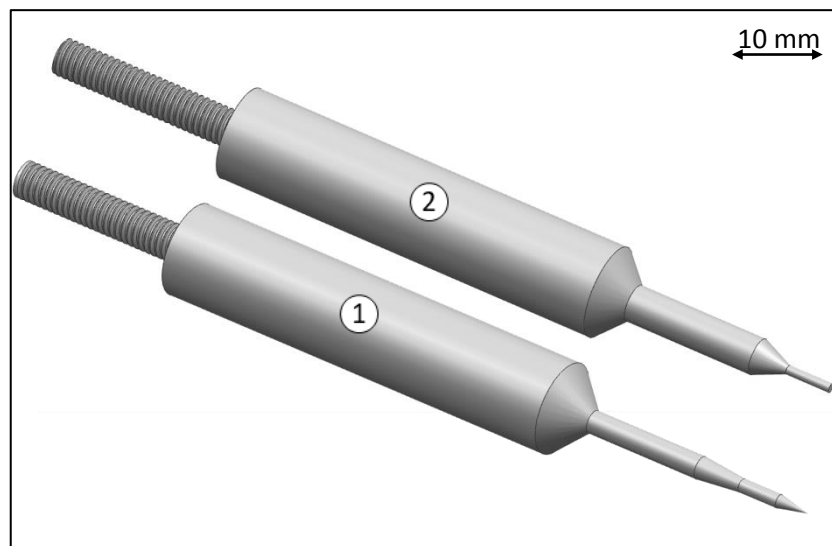

Figure 3. Image of the two measuring tips of the tactile sensor.

The bursting strength according to DIN 53 141-1 is the resistance that a circularly clamped sample offers to a steadily increasing pressure until it bursts. The measured value of the bursting strength is thus given in the unit of a pressure. However, if the area under test remains constant, the result can also be interpreted as a force. A similar constellation is achieved in the sensor when the second measuring tip (2) penetrates the paper object with a flat, cylindrical tip. The force of the tip on the paper surface increases continuously until it bursts. As the second measuring tip continues to penetrate the paper object, the transition from a smaller diameter to a larger diameter is intended to simulate the testing of tear resistance. The laboratory method according to DIN 53 115 measures the work that must be done to tear the sample further after a tear. In the analogy, the penetration of the sensor represents the initial damaging of the paper, while the penetration of the conical part of the measuring tip represents the tearing of the paper.

Sensor data

Figure 4 shows typical force-path curves recorded by the tactile sensor when measuring on a paper object. Basically, both data sets show two local maxima. The first maximum of the first measuring tip (1) is clearly before the first maximum of the second measuring tip (2). This is caused by a difference in length between the two measuring tips, which causes the first measuring tip to touch the paper object before the second measuring tip. The first maximum of the curves is reached by puncturing the object. The second maximum in each case comes from the force required to enlarge the hole as the diameter of the measuring tip increases (3). Due to the analogies mentioned above, the corresponding maximum values from the measurement data are referred to in the further course as puncture force (1), bursting force (2) and tear force (3) of the sensor. These maximum values are extracted using a peak-finding algorithm on the sensor data in Matlab.

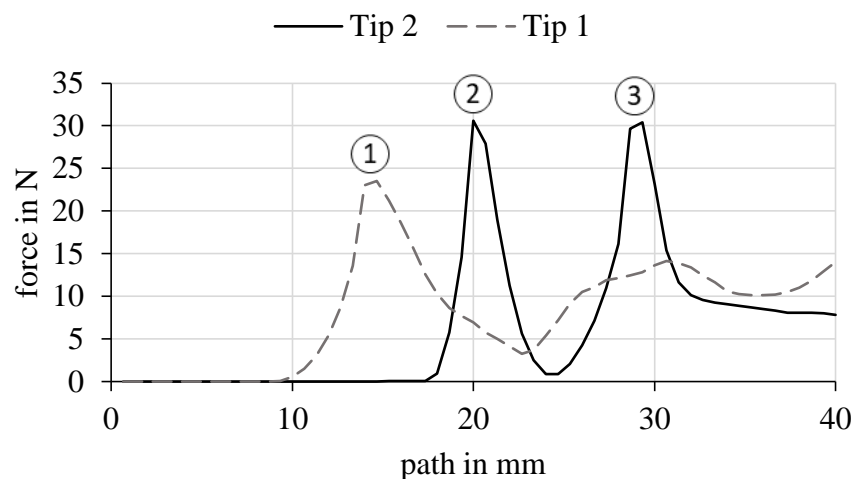

Figure 4. Typical measurement curve of the two load cells of the tactile sensor.

Verification of the sensor data

When selecting objects for the verification of the sensor, the attempt was made to cover as a wide range of strengths as possible. Data of these objects were first recorded with the tactile sensor and then tested in the laboratory. The use of recovered paper objects was not practical for the verification, because the homogeneity of the properties over the entire object could not be guaranteed. Therefore, unused paper and cardboard were used. The tactile sensor was able to collect measurement data for all selected objects, while the laboratory equipment could not be used for all objects. In particular, the tear resistance device was not suitable for thicker cardboard, so that the number of objects measured had to be reduced.

All investigations were carried out several times on similar objects, so that in addition to the mean values, a measure for the scattering of the measured values could be determined. Figures 5 to 7 show correlations between the parameters determined in the laboratory, such as puncture resistance, bursting strength and tear propagation with the corresponding forces of the tactile sensor. All three figures show a good correlation between the laboratory values and the measured values of the tactile sensor. The correlation between the bursting strength and the bursting force is particularly strong with a coefficient of determination of $R^2 = 0.99$. The comparatively large scattering at tear propagation is due to the direction dependence of the measurement, which is due to a

production-related anisotropy in the fiber orientation of papers. The statistics were based on the same number of measurements in machine and cross direction of the papers. However, these results show in particular that the developed sensor fulfils its intended function and can measure mechanical properties of paper objects.

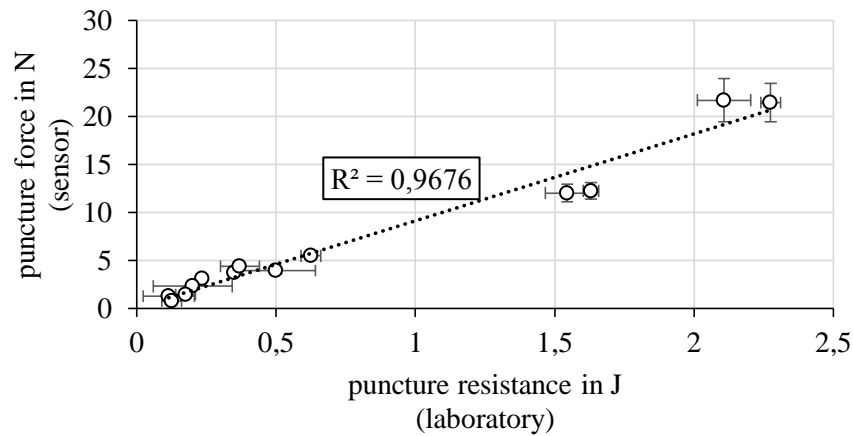

Figure 5. Correlation between the puncture resistance measured in the laboratory and the puncture force measured by the sensor.

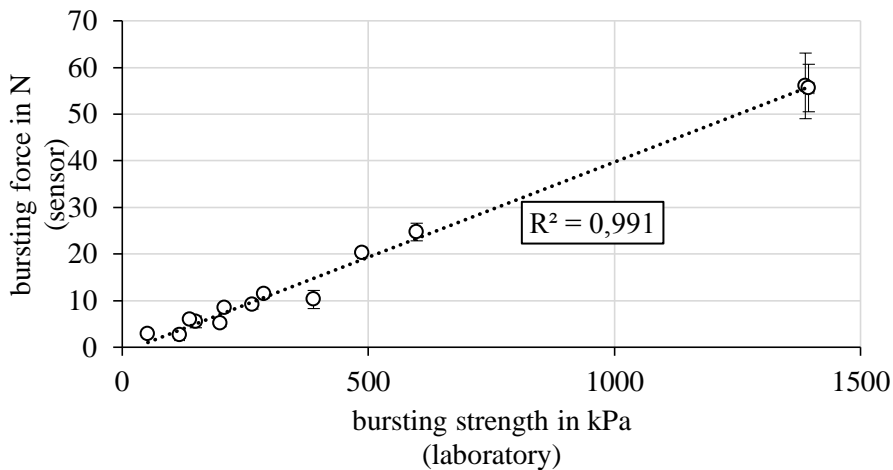

Figure 6. Correlation between the burst strength measured in the laboratory and the burst force measured by the sensor.

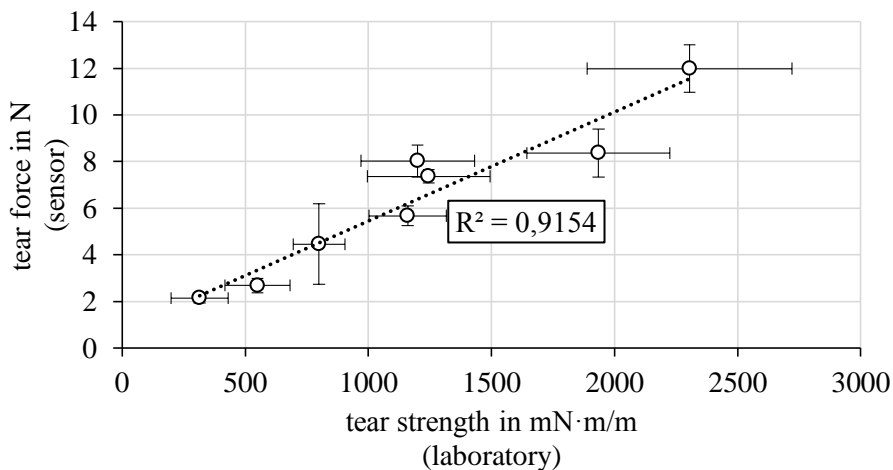

Figure 7. Correlation between the tear work measured in the laboratory and the tear force measured by the sensor.

Conclusions

The sensor presented in this paper allows conclusions to be drawn about the mechanical properties of recovered paper objects. This sensor is used in a measuring system for the classification of recovered paper samples with regard to their composition according to the specifications of the European list of standard grades of paper and board for recycling. It measures force characteristics when penetrating paper objects with specially shaped measuring tips. Before the measurement, the position of the object on an inclined plane is determined with a camera. Via carriages with two degrees of freedom the sensor with the measuring tips reaches the measuring position at the object. In the measuring process, the forces are continuously recorded as the measuring tips penetrate the object. From the force-path curves, the maxima are extracted which are related to the puncture resistance, bursting strength and tear resistance. It could be shown that the forces measured by the sensor show good correlations to the mechanical properties determined in the laboratory according to standardized procedures. Thus, conclusions about the mentioned mechanical properties from the sensor data are possible. The determined mechanical properties can make an important contribution to the classification of paper objects in the measuring system. A verification of the added value of the sensor data for the classification of recovered paper objects is still to be carried out.

References

1. EN 643:2014-05, European list of standard grades of paper and board for recycling.
2. Kumar R. G. P. Mechatronic Design of a Waste Paper Sorting System for Efficient Recycling. - Raleigh, North Carolina, North Carolina State University, Mechanical Engineering, Master's Thesis, 2007.
3. Rahman M. O., Hannan M., Scavino E., Hussain A., Basri H. An efficient paper grade identification method for automatic recyclable waste paper sorting. - In: European Journal of Scientific Research. - 25(2009)1. - S. 96-103.
4. Rahman M. O., Hussain A., Basri N. E. A., Scavino E., Basri H., Hannan M. A. Chromaticity Based Waste Paper Grade Identification. - In: International Arab Journal of Information Technology. - 9(2012)5. - S. 411-417.
5. Rahman M. O., Hussain A., Scavino E., Hannan M., Basri H. Recyclable waste paper sorting using template matching. - In: International Visual Informatics Conference - Kuala Lumpur, Malaysia: Springer Science & Business Media, 2009. - S. 467-478. - ISBN 978-3-642-05036-7.
6. Rahman, M. O., Hussain, A., Scavino E., Hannan M., Basri H. Segregating recyclable waste papers using co-occurrence features. - In: The 9th WSEAS international conference on applied computer science (ACS'09) -, 2009. - S. 187-191.
7. Rahman M. O., Hussain A., Scavino E., Hannan, M. ; Basri, H.: Real-time waste paper grading using CBR approach. - In: International Journal of Innovative Computing, Information and Control, Vol. 8, -, 2012. - S. 471-488. - ISBN 978-3-642-05036-7
8. Rahman M. O., Hussain A., Scavino E., Hannan M. A., Basri H. DNA computing algorithm for recyclable waste paper sorting. - In: Computer Systems Science and Engineering. - 29(2014)5. - S. 361-374. - DOI:
9. Sillat M.-L. Application of hyperspectral imaging in waste paper sorting. - 95 S. - Tallinn, Tallinn University of Technology, Department of Mechatronics, Master's Thesis, 2016.
10. Gottschling A., Schabel S. Pattern classification system for the automatic analysis of paper for recycling. - In: Int. J. Applied Pattern Recognition. - 3(2016)2. - S. 38-58.
11. Klippel P., Zisler M., Schröder F., Schleich S., Serebryanyk A., Schnörr, C. Improvement of dry paper waste sorting through data fusion of visual and NIR data. - In: 7th Sensor-Based Sorting & Control. - (2016).