

**TECHNICAL UNIVERSITY OF MOLDOVA FACULTY OF POWER
ENGINEERING AND ELECTRICAL ENGINEERING**

By way of manuscript

C.Z.U.: 681.527.2:004.42:663.93(043)

ȚURCANU ADRIAN

**INTEGRATED ELECTROMECHANICAL SYSTEMS WITH
NUMERICAL CONTROL FOR COFFEE MACHINES**

222.01- ELECTROTECHNICAL DEVICES AND EQUIPMENT

Summary of the thesis of doctor of engineering sciences

CHISINAU, 2024

The thesis was developed within the Technical University of Moldova, Faculty of Energy and Electrical Engineering.

Scientific Supervisor:

NUCA Ilie, PHD, associate professor, UTM

Official reviewers:

TODOS Petru, PHD, professor, UTM

TÎRȘU Mihail, PHD, scientific associate, IE of UTM

HABA Cristian-Gyozo, PHD, professor, "Gheorghe Asachi" Technical University of Iași, Romania

Composition of the Doctoral Committee for the public defense of the doctoral thesis:

1. CHIORSAC Mihail, President, Dr. Hab., professor, UTM
2. GUȚU-CHESTRUȘCA Corina, scientific secretary, PHD, university lecturer, UTM
3. NUCA Ilie, member, PHD, associate professor, UTM
4. CAZAC Vadim, member, PHD, associate professor, UTM.
5. TODOS Petru, referent, PHD, professor, UTM
6. TÎRȘU Mihail, referent, PHD, scientific associate, IE of UTM
7. HABA Cristian-Gyozo, PHD, professor, "Gheorghe Asachi" Technical University of Iași, Romania

The defense will take place on 05.09.2024, at 12:00 in the meeting of the Doctoral Commission for the public defense of the doctoral thesis within the Technical University of Moldova, Faculty of Energy and Electrical Engineering, str. str. 31 August 1989, 78, study block no. 2, aud. 2-222.

The doctoral thesis and the abstract can be consulted at the Technical University of Moldova library and on the ANACEC website.

The abstract was sent on 29.05.2024

Scientific Secretary of the Doctoral Committee for Public Support,

GUȚU-CHESTRUȘCA Corina,
PHD, university lecturer, UTM

Scientific Supervisor,

NUCA Ilie,
PHD, associate professor, UTM

Author

TURCANU Adrian,



signature

signature

signature

© Turcanu Adrian, 2024

CONTAINED

CONCEPTUAL MILESTONES OF RESEARCH	4
CONTENT OF THE THESIS	13
GENERAL CONCLUSIONS AND RECOMMENDATIONS	38
LIST OF AUTHOR'S PUBLICATIONS ON THE TOPIC OF THE THESIS	40
ABSTRACT (în română, engleză și rusă)	42
PRINT DATA SHEET	45

CONCEPTUAL MILESTONES OF RESEARCH

Timeliness and importance of the topic addressed.

The topicality and importance of the topic addressed are determined by the need to develop and implement integrated electromechanical systems (SEM) based on eco-design principles to increase the quality of the finished product and the energy efficiency of coffee preparation installations and technological processes, reducing their impact on the environment by limiting the use of toxic materials and increased energy consumption.

Reducing energy consumption in technological processes and their influence on the environment fully complies with the provisions of the Environmental Strategy for 2014-2023 approved by Government Decision nr. 301 of 24.04.2014 and Government Decision nr. 102 of 05.02.2013 on the Energy Strategy of the Republic of Moldova until 2030, both at the level of industrial use and domestic needs.

Coffee as a raw material is an unstable product dependent on environmental factors, changing its peculiarities and processing parameters in its technological processing processes. At the same time, these peculiarities and parameters depend on the mixture of coffee varieties and, last but not least, on its degree of roasting. The environmental impact on the technological processes of preparing beverages from coffee beans is more pronounced in autumn and spring when the variation in weather conditions is considerable. The difficulty of regulating the environmentally dependent parameters of coffee machines is also amplified in the context of the lack of a qualified workforce.

Another important moment is energy efficiency. Modern equipment in the coffee bean beverage industry is based on a set of processes for converting electricity into thermal energy in water heating systems, necessary for different processes with varying temperature and flow regimes. For these reasons, the share of electricity consumption in heat transfer processes in liquids and solids is more than 95% the total energy consumption of coffee machines.

The preparation of the drink from coffee beans with the help of coffee makers provides for the processes of grinding or grinding the beans, the dosage of the required amount of ground coffee, and subsequently, the extraction of the desired type of drink. Grinding in modern coffee makers occurs by grinding with a bur or roller. The principle of operation is based on the passage of grains between two disks of different shapes, one of which is stationary and the other rotary, and the grinding fraction depends on the distance between them. The dosing subsystem in modern coffee machines works by dosing by volume or dosing by time. Dosing by volume implies the existence of a dosing chamber with a movable wall connected with a micro-contact to signal the moment of stopping the grinder. In the case of the second type of dosing, the control system of the coffee maker timers the variation of

5-7 seconds, set manually. After stopping, the ground coffee falls directly into the extraction chamber of the brewing unit.

For the most widespread method of espresso coffee extraction, super-automatic coffee machines, and vending machines are equipped with preparation blocks/units, which perform the functions of receiving ground coffee from the dosing block into the extraction chamber, pressing coffee into the extraction chamber, extracting with water itself at temperature, prescribed flow rate and pressure, and disposing of coffee waste after completion of extraction.

The need to develop and implement integrated electromechanical systems with numerical control in order to increase the quality of the finished product becomes a stringency, because constant maintenance of the quality of the coffee product is difficult, and the users of the machines either change the type of coffee beans or do not keep them in recommended conditions. For these reasons, coffee in beans changes grinding peculiarities and most extraction parameters, thus affecting the quality of the finished product. A similar influence on the extraction process is the instability of the environment, especially when placing coffee machines in public street spaces, and the problem of adjustment is amplified because it requires daily adjustment of parameters 3-4 times. This situation outlines the scale of the problem and demonstrates the direct dependence of both the environment and labor on the brewing process of coffee drinks.

In this context, the complex approach of technological processes and the design of a technological installation for the production of coffee bean beverages based on integrated electromechanical systems with numerical control and automatic parameter control would ensure the high quality of the finished product, reducing the influence of external factors and significantly increasing energy efficiency.

The purpose of the work

The general goal of the thesis is to develop and implement advanced integrated electromechanical systems to increase the quality of the finished product and energy efficiency of automated coffee machines.

Research objectives

In order to achieve the proposed goal, the following objectives were formulated in the paper:

Objective 1. Study of technological systems and equipment in the coffee bean beverage production industry.

Specific objectives under Objective 1:

- ✓ Research of technological processes and electromechanical installations for processing coffee beans;

- ✓ Study of the constructive principles of electromechanical systems of coffee machines;
- ✓ Study of electromechanical systems of modern coffee machines and specifics of making espresso coffee extraction method.

Objective 2. Elaboration of innovative constructive–functional concepts of the electromechanical system for coffee machines.

Specific objectives under Objective 2:

- ✓ Synthesizing the construction principles and operating aspects of SEM for automatic coffee machines;
- ✓ Studying the impact of the environment on SEM performance by performing a statistical control of the production process with the collection and processing of statistical data;
- ✓ Processing the collected statistical data and performing statistical analysis using statistical software tools of the production process of coffee bean-based beverages;
- ✓ Research on the impact of electrical and electronic waste (WEE) on the environment, through comparative analysis of legislation in this field;
- ✓ Study of SEM energy efficiency methods for automated coffee machines;
- ✓ Delimitation of new concepts regarding technological equipment for coffee preparation.

Objective 3. Implementation of new technological methods and procedures in electromechanical systems of coffee machines.

Specific objectives under Objective 3:

- ✓ Description of the structure and innovative process of operation of the coffee maker with the implementation of the inductive heater;
- ✓ Development of inductive heater for water treatment;
- ✓ Numerical analysis of flow regulation peculiarities in systems with electromagnetic pumps in state space;
- ✓ Elaboration of SEM with numerical control for automatic adjustment of parameters of coffee extraction equipment;
- ✓ Implementation of SEM with numerical control in the dose settlement process, to reduce the transition time between adjustments;
- ✓ SEM modeling and simulation in MatLab software with SimPowerSystems and Simscape libraries;
- ✓ 3D modeling and inductive heater research in the specialized modeling and simulation software COMSOL MULTIPHYSICS
- ✓ Evaluation of the impact of the patented inductive heater and automatic control system of the grinding system on the performance parameters of the upgraded equipment.

Research hypothesis

The implementation of integrated electromechanical systems based on the control algorithm and advanced technical-scientific solutions for technological equipment in the coffee industry will contribute to:

- Diminishing the influence of external factors on product quality;
- Reducing the transition period of the equipment from the previous adjustment to the new one;
- Increasing the energy efficiency of technological installations for coffee makers.

Scientific novelty and originality of results

The novelty of the paper consists of delimiting problems and identifying possible ways to increase energy efficiency and quality of the finished product by implementing advanced technical-scientific solutions of integrated electromechanical systems for coffee machines.

New scientific results include:

- ❖ The environmental impact study on the performance of the electromechanical systems of the coffee machine was carried out;
- ❖ Control and statistical analysis of the production process of coffee drinks was carried out;
- ❖ The impact of electrical and electronic waste on the environment was researched by conducting a survey on the level of awareness of the population on these effects;
- ❖ The study of energy efficiency methods of electromechanical systems of automatic coffee machines was carried out;
- ❖ The mathematical model of the electromagnetic pump in the space of states and Simscape model of the hydraulic system of the coffee maker with the implementation of variable flow with the use of these types of pumps were developed;
- ❖ For the first time, the design methodology was developed and an inductive heating system was developed for water treatment in coffee machines for which a patent was obtained;
- ❖ Models were developed and simulations of the inductive heater were carried out in the COMSOL MULTIPHYSICS programming environment;
- ❖ Researched the evolution of the quality of the finished product after the implementation of innovations with the use of statistical analysis of performance indicators of the developed electromechanical systems, simultaneously with the evaluation of energy consumption efficiency.

Synthesis of research methodology and justification of selected research methods

For the research of scientific problems proposed for solution and achievement of the objectives outlined in the paper, a systemic approach based on the theory of machines, electric drives, electro technologies, and electrothermal was applied, using the following research methods:

- Logical analysis, induction, deduction, and comparison for research of the current state in the field of technological systems and installations applied in the coffee industry;
- Synthesis using systemic methods and quantitative measurements, to highlight operating peculiarities and other engineering problems in SEM specific to the coffee industry;
- Statistical analysis with the implementation of quality control techniques in the production processes of coffee bean beverages;
- Processing statistical data obtained in the STATISTICA programming environment;
- Modeling of hydraulic systems of coffee machines by State Space method;
- Mathematical modeling and simulations in the MatLab Simulink programming environment using SimPowerSystems and Simscape libraries to evaluate the performance of implemented innovations;
- Mathematical modeling and simulations of physical processes in COMSOL MULTIPHISICS programming environment for the elaborated inductive heater research.
- Comparative analysis to determine energy consumption between the conventional resistive heater and innovative inductive heater and the performance of the latter;
- Analysis of SEM performance indicators of the coffee machine carried out in the STATISTICA software for assessing the impact of innovations on the system and its ability to maintain indicators at optimal parameters.

Implementation of scientific results and applicative value of the work

Applicative value of the work:

1. The study of the performance of electromechanical systems of modern coffee machines was carried out;
2. The correlation coefficient $r = 0.96$ was determined, demonstrating a strong and directly proportional connection between the weight of ground coffee and air humidity;
3. The correlation coefficient $r = - 0.95$ was determined, the magnitude of which demonstrates a very good and inversely proportional relationship between the extraction flow of coffee and air humidity;
4. The thermal energy losses of heating systems in coffee machines in the environment that can reach values of up to 35% have been calculated;
5. Automatic adjustment system with numerical control of the grinder with servo motor and speed reducer can provide the required angular displacement of the grinder adjustment ring

- and move the ring by 6.75 degrees per second with a constant load and by 5.6 degrees per second with a random load;
6. By implementing the adjustable compaction system of the numerical control with a linear actuator, the transition effect of the grinding system from one adjustment to another was diminished. The implemented system ensures a distance of 0.2 meters in less than 3 seconds, the rotor current limits for automatic numerical control being between 1.7÷4.2 and the servo motor temperature during heavy cycles remaining below 70°C;
 7. The implementation of the inductive heater with elaborate numerical control ensures an efficiency of over 55% to the operating process of the coffee machine, with the inductive heater pre-heating time of only 7.6 seconds, which completely eliminates the need to keep resistive heaters pre-heating and maintaining at operating temperature.

Implementation of the obtained results:

The theoretical and practical results obtained in this work were used:

1. Within the economic entity "Coffee Planet Group" SRL, owner of a network of itinerant street trade points, the numerical control system for automatic regulation of the grinder was implemented;
2. Within the economic entity "Coffee Hub" SRL, administrator of a network of coffee bean beverage realization points, the numerical control of the tamping system was implemented;
3. Within the economic entity "M-Consulting" SRL, owner of a network of itinerant street trading points, the inductive heater was implemented as a water treatment element in the coffee machine.

Approval of results obtained

The basic results of the investigation were presented, discussed and approved during several seminars, symposiums and conferences at national and international level:

❖ National:

- **20-25.10.2014** – Conferința tehnico-științifică ale colaboratorilor, Doctoranzilor și Studenților, Universitatea Tehnică a Moldovei, Chișinău, Moldova, 2014.
- **09.12.2016** – Conferința tehnico-științifică ale colaboratorilor, Doctoranzilor și Studenților, Universitatea Tehnică a Moldovei, Chișinău, Moldova, 2016.
- **09.12.2019** – Conferința tehnico-științifică ale colaboratorilor, Doctoranzilor și Studenților, Universitatea Tehnică a Moldovei, Chișinău, Moldova, 2019

❖ International:

- **27-28.06.2014** – Sesiunea de comunicare științifică a studenților FIESC - ELSTUD 2014 Suceava, România. Premiat cu premiul al treilea

- **09-10.10.2014** – Conferința națională de acționări electrice, Reșița, România, , CNAE XXI 2014;
- **20-23.10.2015** – 5th International Conference, Telecommunications, Electronics and Informatics, Chișinău, Republica Moldova, ICTEI 2015.
- **06-08.10.2016** – International Conference on Applied and Theoretical Electricity, Craiova, România, ICATE 2106
- **10-12.05.2017** – International Conference on Applied Sciences, Hunedoara, Romania, ICAS 2017;
- **11-13.10.2017** – 11th International Conference On Electromechanical And Power Systems, Iași, Chișinău, SIELMEN 2017
- **01-03.07.2020** – 15th International Conference Mechatronic Systems and Materials, Bialystok, Poland, MSM 2020

Scientific publications

On the topic of the thesis were published 9 scientific papers, including 3 as sole author and 1 patent. The main results were exhibited at various national and international conferences, a total of 10, including Romania, Poland, with the publication of 3 papers in IEEE Xplore, 5 papers in SCOPUS, 4 WoS papers.

Summary of thesis chapters

The doctoral thesis was elaborated in accordance with the requirements submitted by the National Agency for Quality Assurance in Education and Research. The thesis includes an introduction, 3 chapters structured in paragraphs, annotation in Romanian, English, and Russian, a list of tables, figures, and abbreviations used, general conclusions and recommendations, a bibliographic list of 110 titles, and 16 annexes. The total number of pages of the paper is 151 (up to the bibliography), containing 125 figures and 31 tables.

The **Introduction** presents the argumentation and actuality of the researched topic. It formulates the purpose, main objectives, and specific objectives, the elements of the scientific novelty of the obtained results, the theoretical significance and applicative value of the field of study, and the results obtained.

Chapter I of the thesis *The current state of play in the field of electromechanical systems of coffee machines* presents the typical technological processes in coffee bean processing as well as the evolution of electromechanical systems of coffee industry installations, the construction principles of SEM in coffee machines and the performance of these systems are analyzed, highlighting espresso extraction methods in modern coffee machines. Also, a series of shortcomings of modern

technological installations in the coffee industry were delineated, on which research in the following compartments will be focused.

Chapter II of the thesis *The elaboration of constructive-functional concepts of the electromechanical system for coffee machines* is the compartment where the constructive principles and aspects of SEM of coffee machines are investigated, the problems generated by the influence of the external environment on the parameters specific to the production process of coffee bean beverages are determined, the processes with the use of statistical methods and software are studied respectively to establish the impact of the environment on the performance of the electromechanical systems of the automatic coffee machine, using the processes of collection, processing, analysis and statistical control of coffee beverage production. Also, research was carried out on the impact of coffee machine waste on the environment, with a survey on the level of awareness of the population. This research is followed by an analysis of methods of energy efficiency of processes in the electromechanical systems of the device, which allowed the identification of new concepts of technological equipment for coffee preparation.

Chapter III of the thesis *The implementation of new technological methods and procedures in electromechanical systems of coffee machines* represents the applicative part of the work. In this compartment are numerically investigated the electromechanical systems of the coffee machine with the use of inductive heater, for which a patent was obtained with no. 1617 and no. Deposit S2020 0005. The description of the structure and innovative operating processes of the coffee machine with the implementation of the inductive heater was followed by other numerical research, including the methodology of sizing the inductive heater for water treatment, numerical analysis, and modeling in the state space of the peculiarities of flow regulation in systems with electromagnetic pumps, modernization of the grinding system by implementing the numerical control of automatic regulation of grinder, reducing the transition time from the previous adjustment to the present one by using the numerical control of the settlement process. The chapter continues with creating models in the MatLab Simulink programming environment, including the hydraulic system using the Simscape library and the electromechanical grinder adjustment system using the SimPowerSystems library. In the COMSOL MULTIPHIZICS programming environment, 2D Axial and 3D models of the inductive heater were created to simulate electromechanical, thermodynamic, and hydraulic processes. Finally, the impact of the patented inductive heater and the automatic control system of the grinding system on the performance parameters of the coffee machine is analyzed; it is established where energy losses occur in the operation of resistive boiler systems, the energy consumption between the resistive heater and the inductive heater is compared, and the evolution of the performance indicators of the grinding system is determined.

Each chapter of the paper ends with presenting the basic conclusions and the specification of the main results obtained.

In, *Conclusions and recommendations* are synthesized the obtained results and recommendations regarding the implementation in practice of the technical-scientific results of the thesis.

CONTENT OF THE THESIS

The **Introduction** presents the argumentation and actuality of the researched topic. It formulates the purpose, main objectives, and specific objectives, the elements of the scientific novelty of the obtained results, the theoretical significance and applicative value of the field of study, and the results obtained.

Chapter I of the thesis The current state of play in the field of electromechanical systems of coffee machines presents the typical technological processes in coffee bean processing as well as the evolution of electromechanical systems (SEM) of coffee industry installations, the constructive principles of SEM in coffee machines and the performance of these systems are analyzed, highlighting espresso extraction methods in modern coffee machines. In addition to the performance of such equipment, there are also shortcomings. The impossibility of automatic adjustment of grinding equipment parameters makes the influence of the variation of raw material state and environment on the process significant, while energy consumption in thermodynamic processes is considerable. The typical technological processes in coffee bean processing have many steps until they are enjoyed as a hot drink in the cup during breakfast every morning. The quality of the finished product is influenced by each of those steps [1]. **Figure 1** shows the flow diagram of the coffee bean processing steps.

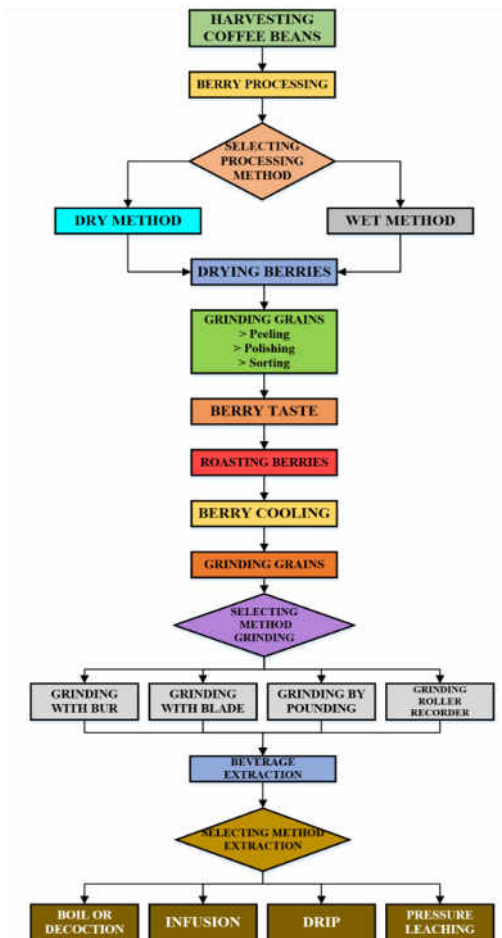

Fig. 1. Flow diagram of coffee bean processing steps

The stages, starting with the selection of the grinding method and ending with extraction, are carried out at the place where the finished product is consumed or realized.

Taking into account the processing steps presented above, all coffee makers can be divided into several groups as follows:

1. **Professional coffee machines** are designed for a very large number of servings during the total life of the machine. The recovery period, the return to stationary operation after the previous extraction, is very small or almost zero from one espresso to another when the temperature of water and steam must return to the prescribed value.
 - 1.1. **Lever espresso machines** – these types of machines do not have a pump to create water pressure through the extraction group, and instead a lever piston is used;
 - 1.2. **Pump-driven espresso machines** – these are machines that force water through ground coffee with a pump driven by a single-phase asynchronous motor;
2. **Semi-professional coffee machines** (machines for households and offices) are designed for reduced productivity, with lower boiler capacity and availability of pressurized filter units for semi-automatic, automated classes and super-automatic espresso machine preparation units. These machines can be grouped as follows:
 - 2.1. **Semi-automated machines** have automatic control of water temperature and steam pressure, but water dosing in the espresso brew is not available and must be done manually by pressing the start and stop buttons;
 - 2.2. **Automatic electronic.** This type of machine has, in addition to the automatic system of semi-automatic machines shown above, an electronic system with a series of programmable buttons that can be set for different quantities of coffee, and the machine doses the exact amount of water needed for a particular drink;
 - 2.3. Super-automated **machines** are the most sophisticated, with a fully automated process that starts with grinding the beans with the proper fineness, places the ground coffee in the brewing capsule of the extraction unit, handles the coffee, and extracts the required amount of beverage, which is dosed with the flow meter integrated into the system. The electronic digital control system with a programmable CPU offers a wealth of possibilities and useful functions:
 - **Rinse function** – this function rinses the waste water out of the circuit every time the machine is adjusted, and the water temperature is below 50°C.
 - **Descaling function** – the system can be programmed to measure the amount of water passed through the boiling system and require the descaling process after every 500 liters

of water at hardness 1, 300 liters for hardness 2, 150 liters for hardness 4, and 80 liters for hardness 4.

- **Pre-grinding** - this function is meant to reduce brewing time by grinding coffee beans in advance.
- **Pre-brew** - when this function is activated, after compaction, the coffee is moistened before the actual brew. This action makes coffee more aromatic.
- **Total coffee** – the control system counts the indicator of the amount of coffee.

As a result of researching all aspects of the extraction process, a series of technical parameters were systematized, which were subsequently standardized by the Italian National Espresso Institute and are presented in **Table 1**.

Table 1. Technical parameters outlined by the Italian National Espresso Institute for making certified Italian espresso

ELEMENT	PARAMETER
Portion of ground coffee	7.0 ± 0.5 g
Water outlet temperature	90 ± 3°C
Temperature in the cup	67 ± 3°C
Incoming water pressure	9 ± 1 bar
Percolation time	25 ± 5 sec.
Volume in cup (including crema)	30 ± 2.5 ml

In addition to water temperature and flow, pressure inside the extraction chamber plays an essential role for extraction. It is the pressure and flow of water that achieves sufficient and rapid extraction to obtain the essential oils from ground coffee in the form of a cream.

Taking into account the above and the technical possibilities of modern electromechanical installations, three extraction solutions and techniques can be highlighted which are explained below:

1. **Non-pressurized portafilter extraction** – these types of filter holders have a simple construction, consisting only of a metal filter with hole diameters small enough not to allow ground coffee to pass through them, mounted in the filter holder and maintained in their working position by a mechanical fixing spring;
2. **Extraction with pressurized portafilter** - these filter holders, contrary to those described above, have a system inside them in the form of an exhaust valve, which controls the pressure inside and keeps at the level of 9 bar regardless of the fineness of the ground coffee. The construction of these valves differs from one manufacturer of compressors to another;
3. **Unit extraction of preparations** (extraction group). In 1985, SAECO introduced the preparation/extraction unit for the first time. It offers the possibility to automate the extraction process fully. With the introduction of the brewing unit, the company started the production of

coffee machines, which automated the entire extraction process, from grinding coffee beans to making perfect espresso with just a push of a button. The brewing unit performs four very important actions while preparing the espresso:

- Receives ground coffee from the dispenser,
- Compress coffee in brewing capsule,
- It directs pumped water of 92°C through the coffee capsule with 9 bar pressure, controlled by the exhaust valve, which is built into the unit.
- Dispose of used coffee in the used coffee drawer.

In (figure 2) is shown the SAECO extraction unit from the Royal Digital Plus espresso machine.

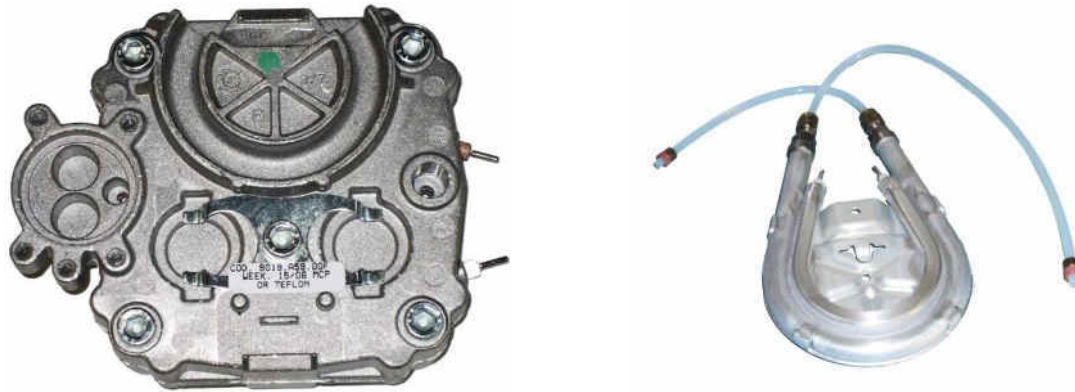

Fig. 2. SAECO Royal Digital Plus coffee brewing unit [11]

The electromechanical system of each espresso machine can consist of several subsystems that ensure the exact conditions for the correct preparation of coffee and steaming for the treatment of milk used in beverages such as latte or cappuccino. The total number of subsystems in a machine depends on its automation class, and these subsystems can be:

1. **Boiling system** – this system must ensure the proper characteristics of water and steam. These two states of water to be produced by the system have different parameters and must be produced concurrently. The hot water in the extraction group should be 90-93°C with the pressure of 9-10 bar, and the steam in the cappuccino between 1-1.2 bar, which corresponds to approximately 120° C. These conditions can be provided by several models:
 - 1.1. **Multisection boiler** – the boiler has a multisection design with different temperatures and pressures for all extraction processes, from espresso to milk processing, and only one heating element is used as a source of thermal energy.
 - 1.2. **Multi-boiler design** – this type of heating system is based on the idea of separating heating processes. In the electromechanical system is provided one or more boilers for espresso extraction, depending on the number of extraction heads, and a boiler for steam production.

1.3. **Design of single-section boilers** – this type of boiler has only one section and can deliver water or steam with a single thermal and pressure parameter, and productivity is lower. For these reasons, such a type of boiling system is used more in semi-professional and super-automated coffee machines. **Figure 3** shows two types of instantaneous water heaters used in SAECO super-automatic machines.



a)

b)

Fig. 3. SAECO ROYAL series water heaters [11]

a – Continuous flow boiler for espresso and hot water

b – Pipe boiler for instant and fast steam systems

To overcome the disadvantages of these types of boilers, which are manifested in the inability to simultaneously generate water in different states and temperatures, manufacturers of super-automated type coffee makers implement different heating systems with one or more boilers.

2. **Automatic pumping and water delivery system** – is designed to monitor the water level in the boiler or boilers depending on the type of heating system of the appliance and the supply of water to the appliance, both to ensure the necessary level of water in the steam boiler and the water flow in the extraction process with the ability to increase water pressure up to 9-10 bar.

2.1. **Rotary vane pump** - this is a positive displacement pump, designed for pumping moderately aggressive water and liquids with low flow and high pressure.

2.2. **Magnetically coupling pumps**—MG series magnet gear pumps are compact, performance, and precision pumps for advanced technological applications. The magnet drive principle provides a fully sealed pumping chamber capable of safely handling a wide range of corrosive liquids.

2.3. **Rotary vane pump-motor units with magnetic coupling**—This is an integrated BLDC pump-motor unit in case the motor has no moving parts. It features a compact size coupling, superior performance, low power consumption, and quiet operation to provide great versatility in a refined design and advanced technology.

2.4. **TP30 Series Peristaltic Pump**—Peristaltic pump technology provides precise, efficient fluid transport flow and is implemented in various industries. The key to its design is the elimination of traditional reducers and the possibility of fast pump servicing, which allows changing the tube or unit entirely with minimal knowledge.

2.5. **Solenoid pumps (electromagnetic)** – are composed of an inductor inside which the core moves, which has the shape of a cylinder. Due to the movement of this core, caused by the electromagnetic field generated by the inductor, it has its water pumping.

3. **Grinding system**—The grinding system grinds coffee beans, doses the required amount, and transfers it to the extraction unit.

In the results of the research, there were delimited a number of exact production parameters necessary to maintain for the qualitative development of the technological process; at the same time, the analysis of the performance of the equipment in the field demonstrated their inability to ensure the necessary quality. Further, the research will focus on the analysis of engineering problems, which have a major impact on the quality of the finished product and the implementation of solutions to increase the quality and energy efficiency of automated coffee machines.

In *Chapter II Elaboration of constructive-functional concepts of the electromechanical system for coffee machines*, the constructive principles and operating aspects of SEM of coffee machines are investigated, the problems generated by the influence of the external environment on the parameters specific to the production process of coffee bean beverages are determined, the processes are studied with the use of statistical methods and the respective software to establish the impact of the environment on the performance of the electromechanical systems of the automatic coffee machine, using the processes of collection, processing, analysis and statistical control of coffee beverage production. Also, research was carried out on the impact of coffee machine waste on the environment, with a survey on the level of awareness of the population. These researches are followed by an analysis of the methods of energy efficiency of the processes in the electromechanical systems of the device, which allowed the delimitation of the new concepts of the technological equipment for coffee preparation, approached in the subsequent study process.

Coffee makers of the super-automated class are the most sophisticated and technological. In the process of extracting a portion of espresso, the electromechanical system of the machine must perform a series of actions: grind the coffee beans to the required fraction; dose the amount of coffee needed for a can of coffee; pump water through the heating system into the brewing unit, where the water temperature is raised from $10^{\circ}C$ up to $93^{\circ}C$; dispense espresso and steam when needed. The methodology was developed and the calculations of the parameters of the typical components used

in coffee machines of the respective class were developed, and their structural diagram is represented in **fig. 4**.

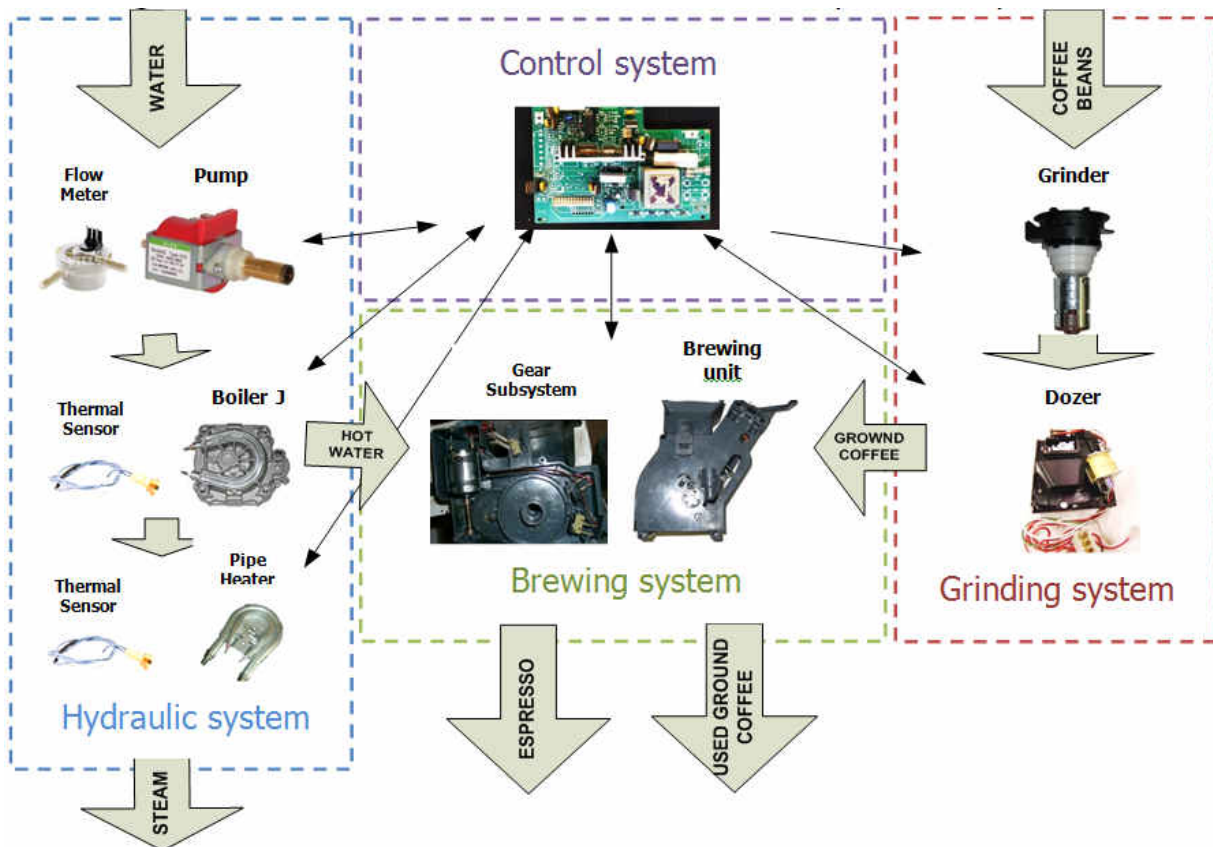

Fig. 4. Diagram of the super-automatic electromechanical system of the SAECO ROYAL series [elaborated by the author]

In order to fully understand the limits of the performance of the electromechanical system of the researched automatic coffee machine and to conduct a critical analysis of all the disadvantages of these systems, the standard operating processes of the automatic coffee machine researched above were researched. As a result of this research, all the functions of the device were studied, and based on the data obtained, the flow diagram of the operating process of the respective automatic device was built, which is represented in **Figure 5** below.

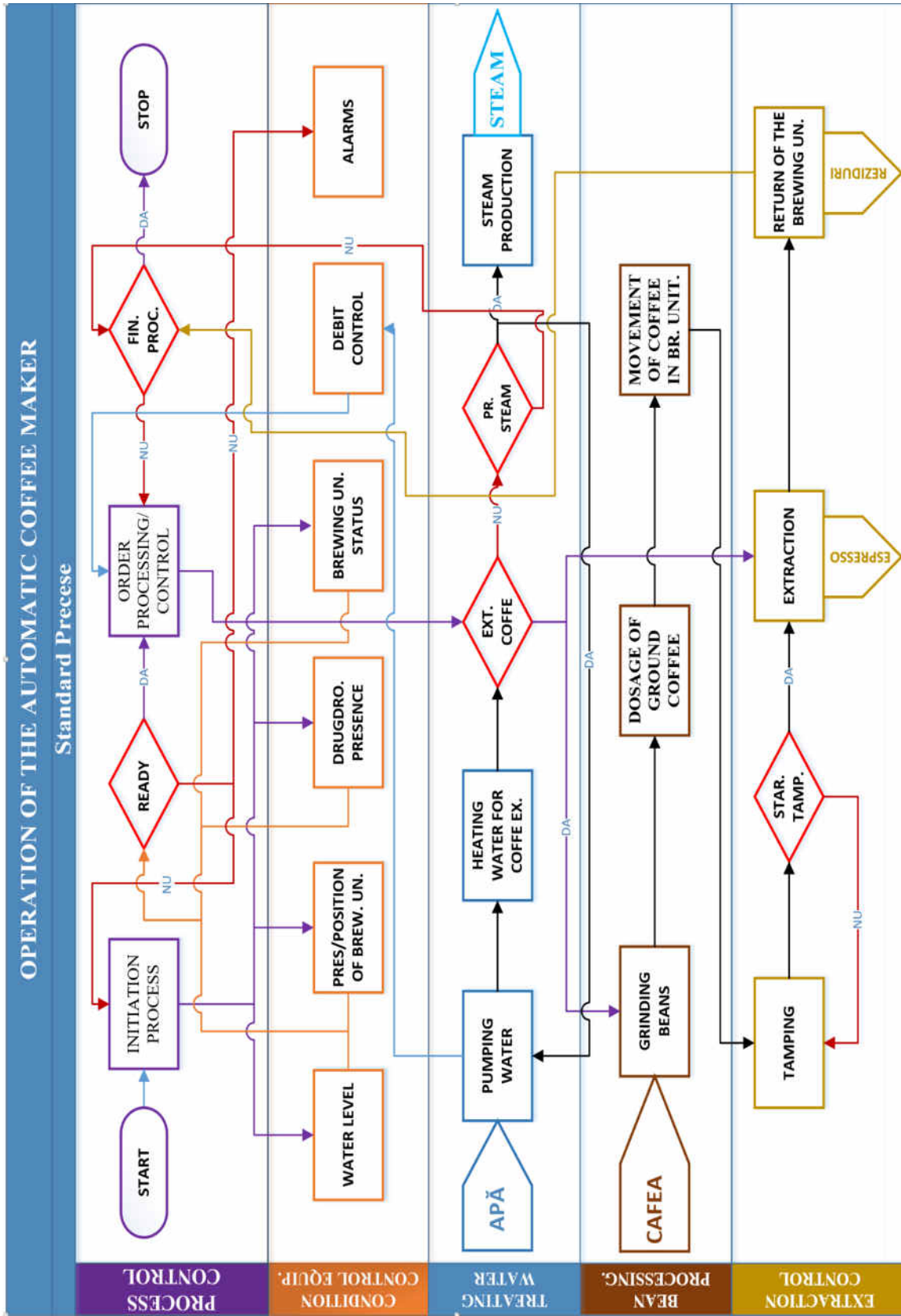

Fig. 5. Flow diagram of the standard operating process of the automatic coffee maker [developed by the author]

From practice it has been found that the main problems that greatly affect the quality of a coffee drink are the quality of the coffee beans and the condition/parameters of the extraction water. The control system of a coffee machine can provide the required quality of water temperature, pressure, flow rate, and duration of the leaching/extraction process, but the grinding process automatically remains unadjustable. This process is directly influenced by the quality of coffee beans, namely the composition of coffee, the moisture level of the environment, and excessive uncontrolled drying of the beans.

For the analysis of the extraction process from a statistical point of view, experimental extractions were carried out using a professional coffee machine with unpressurized filter holders, a highly productive grinder equipped with equipment for measuring the temperature and humidity of the external environment, and a high-precision electronic scale. Subsequently, statistical data were collected based on which analyses were carried out. The data were collected in various weather conditions, ensuring both variation in the temperature of the external environment and variation in its humidity.

From the results of the X-bar and R Chart analysis in **figure 6**, it can be seen that the grinding flow rate is slightly influenced by the external environment, while the density of ground coffee in the dose varies greatly.

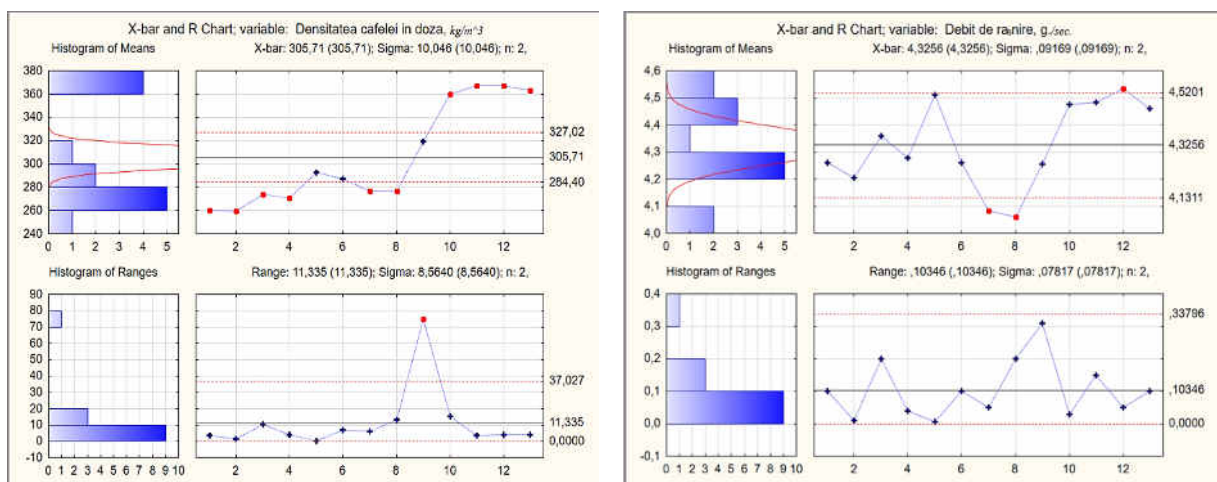

Fig. 6. X-bar and R Chart analysis for coffee density in the compacted dose corresponding to grinding flow. [elaborated by the author]

The influence of the external environment on the process is also demonstrated by the analysis of SixGhaph X-bar and R Chart for extraction flow in **figure 7**

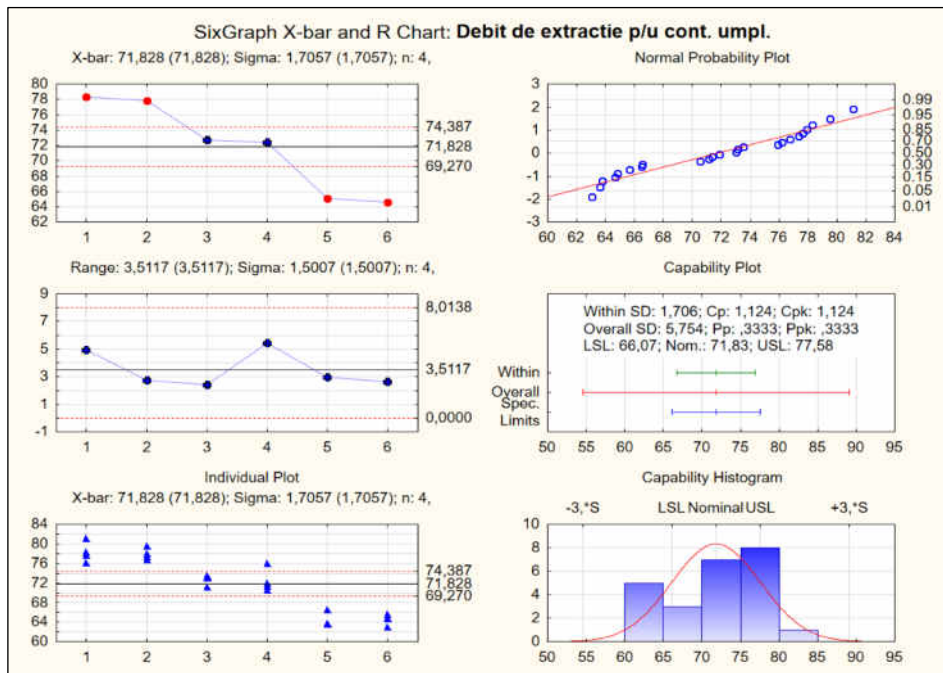

Fig. 7. Analysis of SixGraph X-bar and R Chart for calculated extraction flow rate for a filled container [developed by the author]

Following the analyses carried out, it was found:

- The descriptive statistics tools showed the influence of air humidity on the researched production process.
- With increasing air humidity, the fraction of ground coffee decreases, respectively, the grinding rate of coffee beans decreases
- According to the Colton classification, the correlation coefficient of $r = 0.96$ between the weight of the ground coffee of the filled container and the humidity shows a strong connection between them, which is directly proportional.
- The correlation coefficient $r = -0.95$ between the extraction flow rate with filled container and moisture demonstrates an inversely proportional relationship.
- In the QC diagrams it can be emphasized that the variation of air humidity influences the grinding process, which results in a variation in the density of the ground coffee in the filter container and the effect of diminishing the grinding flow.

In the process of evaluating the energy consumption of the coffee machine, measurements were made and data was collected, based on which the histogram of energy consumption distribution for three extraction processes was built, including a 105-second break. (Figure 8.)

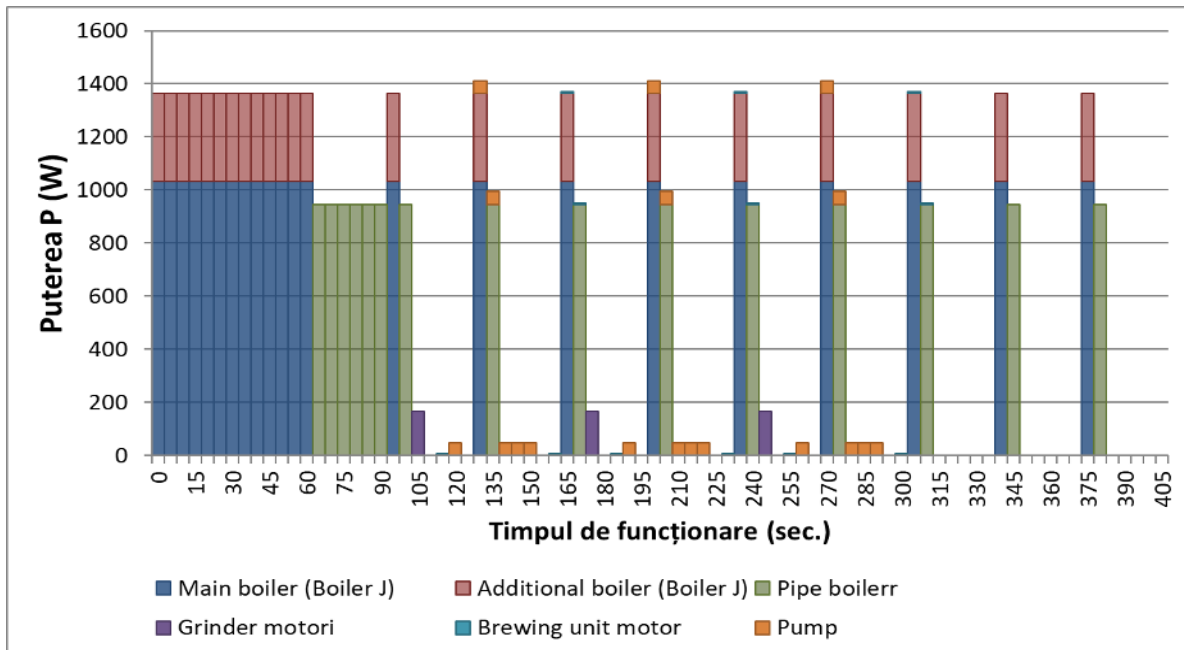

Fig. 8. Histogram of the distribution of total energy consumption for three extraction processes, including a break of 105 seconds [elaborated by the author, 39]

Subsequently, the collected data were systematized and included in **Table 1**.

Table 1. Table of energy consumption of the coffee maker [elaborated by the author, 39]

ELEMENTS OF THE ELECTROMECHANICAL SYSTEM	RATED POWER, P_n (W)	OPERATING TIME, t (sec.)	POWER CONSUMPTION, E (Wh)	ENERGY CONSUMPTION, E (%)
1. Main heater	1034	105	33,51	49,04
2. Additional heater	330	105	10,69	15,65
3. Tubular heater	946	75	21,90	32,05
4. Coffee grinder	168	15	0,78	1,14
5. Drive motor of the preparation unit	6	60	0,11	0,16
6. Pompa	48	90	1,33	1,95
TOTAL ENERGY CONSUMPTION			68,32	100,00

The data obtained show that about 99% of the total energy consumption belongs to the hydraulic system, of which 97% is used for heating water and 2% for pumping it. This will serve as a basis for focusing research on streamlining the coffee extraction process by optimizing the operation of the hydraulic system.

At the same time, the numerical research of the performance of the hydraulic system of the coffee maker, in which the problems of electricity consumption and increasing the energy efficiency of technological processes with the use of typical installations were analyzed, concluded the following:

- The use of thermal insulation of components of systems transforming electricity into thermal energy in order to reduce heat and electrical energy losses through convective heat transfer losses can result in an energy saving of up to 35% in those processes;

- The implementation of adjustable electric drives in various systems and mechanisms with the use of electric motors allows the efficiency of installations by over 40%;
- As a result of the abovementioned changes, we can increase energy savings in coffee machines by over 37%. At the level of a single installation, this figure does not seem high, but if we try to make a calculation at the level of locality or country, this figure becomes much more significant.

As a result of the research, three research directions have been outlined on which further work will be carried out and which, subsequently, will have a maximum impact in order to increase the quality of the finished product and the energy efficiency of these installations. Those directions will be further outlined:

- ❖ **Automatic grinder adjustment system** – automating the grinder adjustment process will reduce the impact of the environment and unqualified personnel on the quality of the finished product.
- ❖ **Numerical control system of burring/compaction** – burring/compaction system with numerical control, which will allow reducing the impact of the transition from the previous adjustment of the grinder to the new one by compensating the under-adjustment or over-adjustment in transient moments with variable settlement pressure.
- ❖ **Hydraulic system** – implementation of the electromechanical system of the innovative coffee machine with an inductive heater will increase the energy efficiency of the coffee machine.

Figure 9 shows the structural diagram of the constructive-functional concept of the electromechanical system of the innovative coffee machine with inductive heater, which is to be changed by implementing innovative technologies.



Fig. 9. Structural diagram of the electromechanical system of the innovative coffee machine with inductive heater [developed by the author]

Chapter III of the thesis The implementation of new technological methods and procedures in electromechanical systems of coffee machines represents the applicative part of the work. In this compartment are numerically investigated the electromechanical systems of the coffee machine with the use of inductive heater, for which a patent was obtained with no. 1617 and no. Deposit S2020 0005. Next, the inductive heater caps, grinder control system, and mathematical model of the electromagnetic pump in state space were methodologically developed and realized.

The chapter elaborates on models of the grinder adjustment system, the settlement system with numerical control, and hydraulic systems using valve props and electromagnetic pumps made in the MatLab Simulink programming environment, using SimPowerSystems and Simscape libraries. and the COMSOL MULTIPHIZICS programming environment. Finally, the impact of innovations on the performance parameters of coffee machines is analyzed; it is established where energy losses occur in the operation of resistive boiler systems, the energy consumption between resistive heater and inductive heater is compared, and the impact of innovations on the performance indicators of the grinding system is determined.

Figure 3.10 shows the diagram of the operating flow of the coffee machine with the implementation of additional innovation processes. Additional processes include the process of collecting data from previous extractions, grinder control blocks and burring process control, which will allow increasing the quality of the finished product, and the inductive boiler will allow considerably increasing the energy efficiency of the heat transfer process.

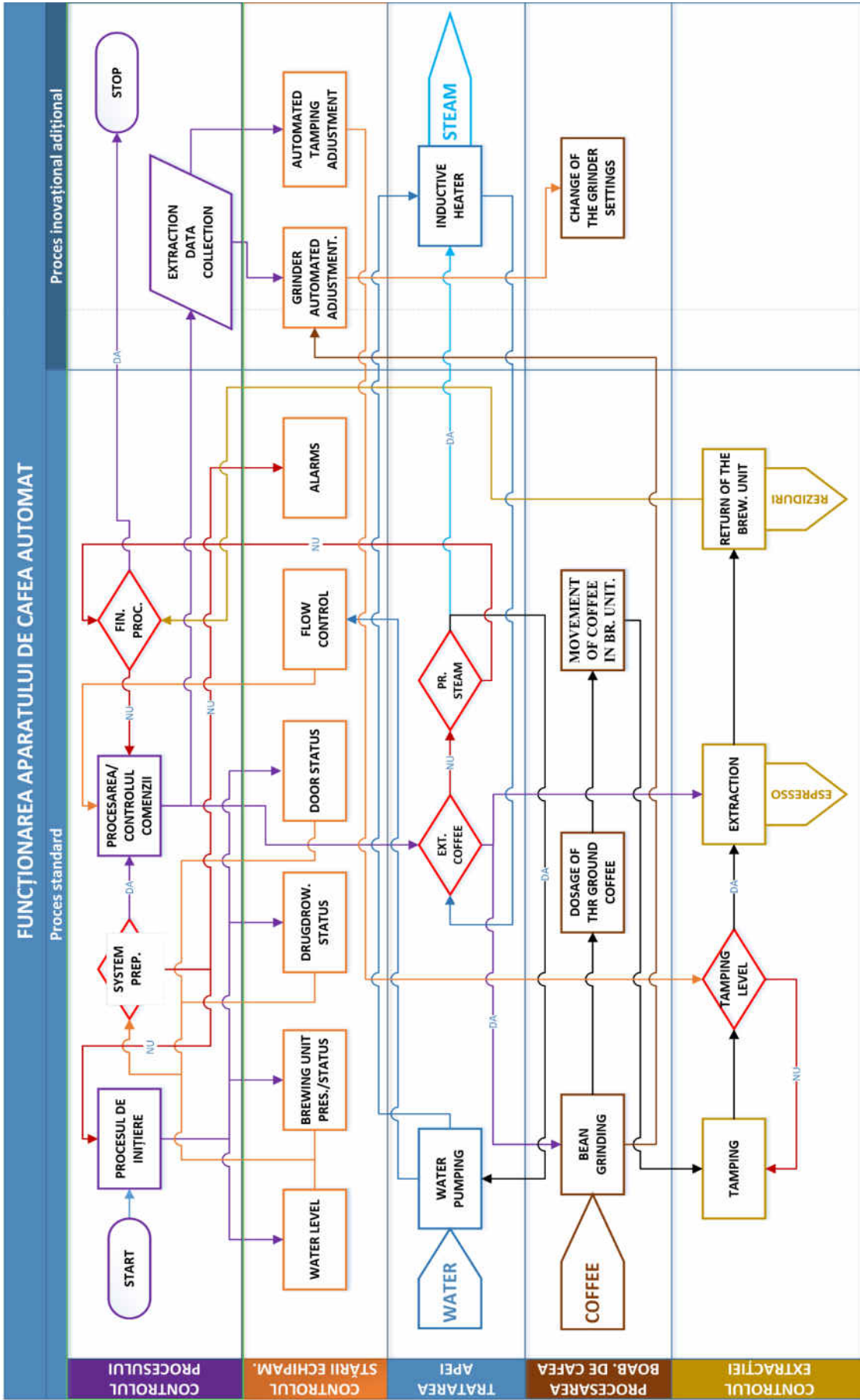

Fig. 10. Flow diagram of the operation process of the automatic coffee machine with the implementation of additional innovative processes [developed by the author]

In order to increase the efficiency of thermodynamic processes, the construction of a new inductive-type heater was proposed and patented (**figure 11**). It contains the inductor (8) which consists of 7 turns, made of a copper tube, parameters of which are dimensioned to travel the current of over 200 A with a frequency of about 100 kHz. The inductor is wound around the workpiece which consists of two pieces in the form of hollow rings made of represented ferromagnetic material: the outer cylinder (5) and the inner cylinder (7).

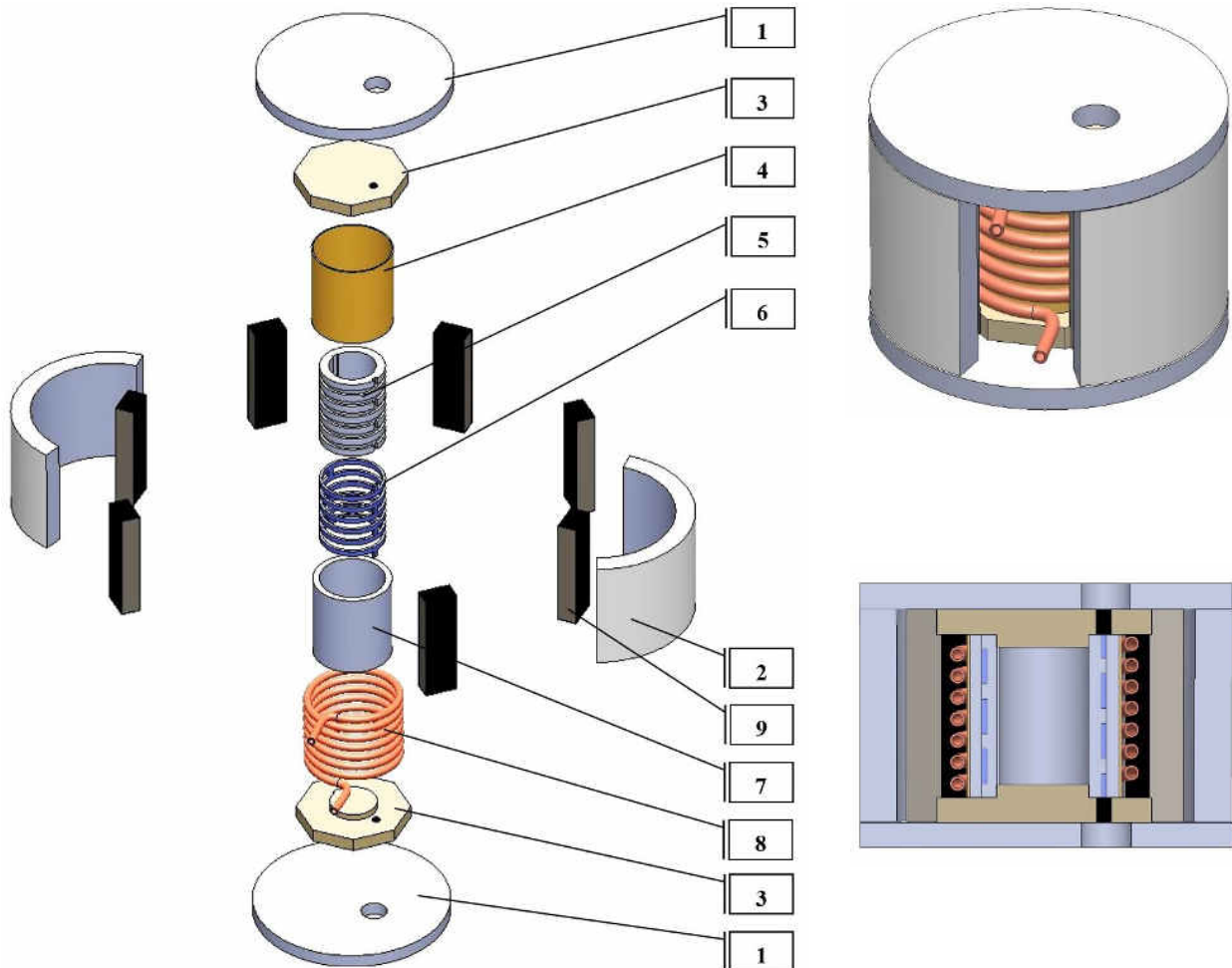

Fig. 11. Final representation of the inductive heater with all parts included [elaborated by the author, 40]

On the outside of the inner tubular ring, cuts of such shape and length are made so that when assembling these tubular rings, a channel is obtained for the passage of the fluid to be heated. The shape of the channel obtained in the figure is represented by the figure (6). To ensure much higher flows and temperatures of the heated fluid than those dimensioned, both in the hot water generation regime of about 90°C and in the steam generation regime of 120°C, the inductor can be forcibly cooled by pumping a caloportor agent inside the copper tube, thus ensuring the stability of the heater. To avoid short circuits, the inductor is isolated from the workpiece using an insulator (4) with high thermal resistance, and its turns are removed from each other. To reduce magnetic field losses on the outside of the inductor, electrotechnical steel sheets (9) are added, which in turn are kept spaced away

from the inductor by means of side shields (3). These shields position both the sheets of the magnetic circuit and the workpiece. In order to decrease heat losses in the environment, the inductive heater is also provided with thermal protection made by thermal insulation elements (1) and (2) of the heater, made of a material with high thermal resistance and low thermal conductivity coefficient^t. [40]

The 2D Axial and 3D model in COMSOL MULTIPHISICS environment was developed, based on the 3D model of the inductive heater made in the SOLIDWORKS environment, the graph of water temperature evolution in the water channel of the workpiece in preheating mode was obtained. (Figure 12)

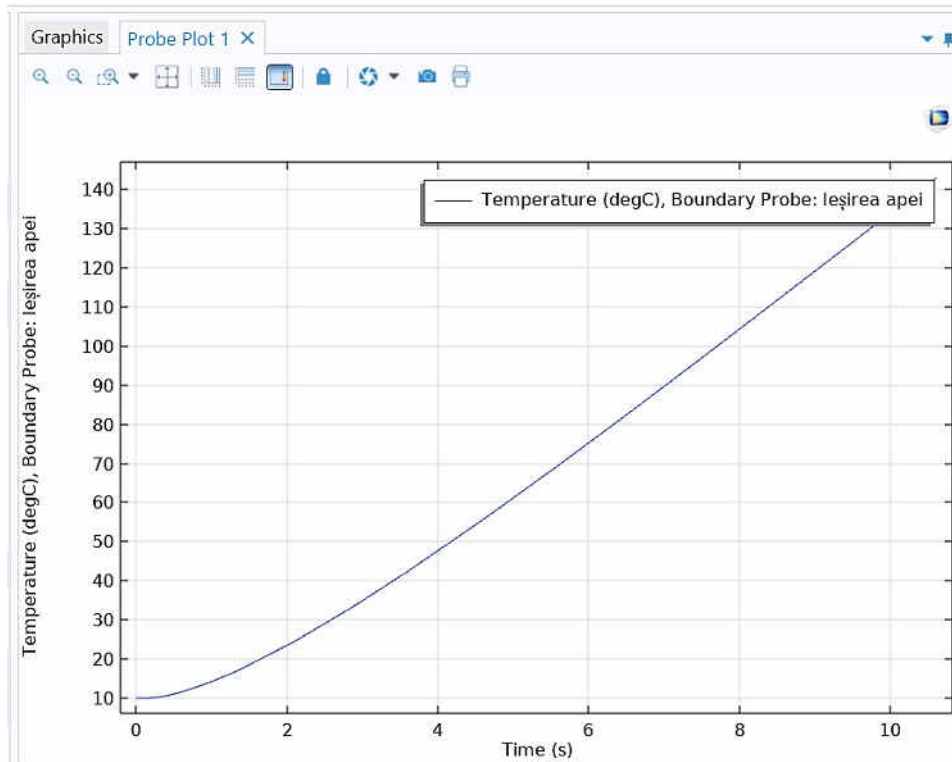

Fig. 12. Graphical representation of the evolution of water temperature in the channel of the workpiece in preheating mode [elaborated by the author]

The graph of the variation of water temperature in the channel of the workpiece in the obtained pre-heating process shows that the water temperature after the 1.5th second increases almost linearly. The temperature of 90°C is reached at the 7th second and the required calculated temperature of 100°C at the workpiece surface at the 7.6th second of the pre-heating process. Continuing the pre-heating process will allow the heater temperature value of 120°C to be reached at the 9th second of the pre-heating process.

Figure 13 shows the current density obtained in the workpiece and inductor turns.

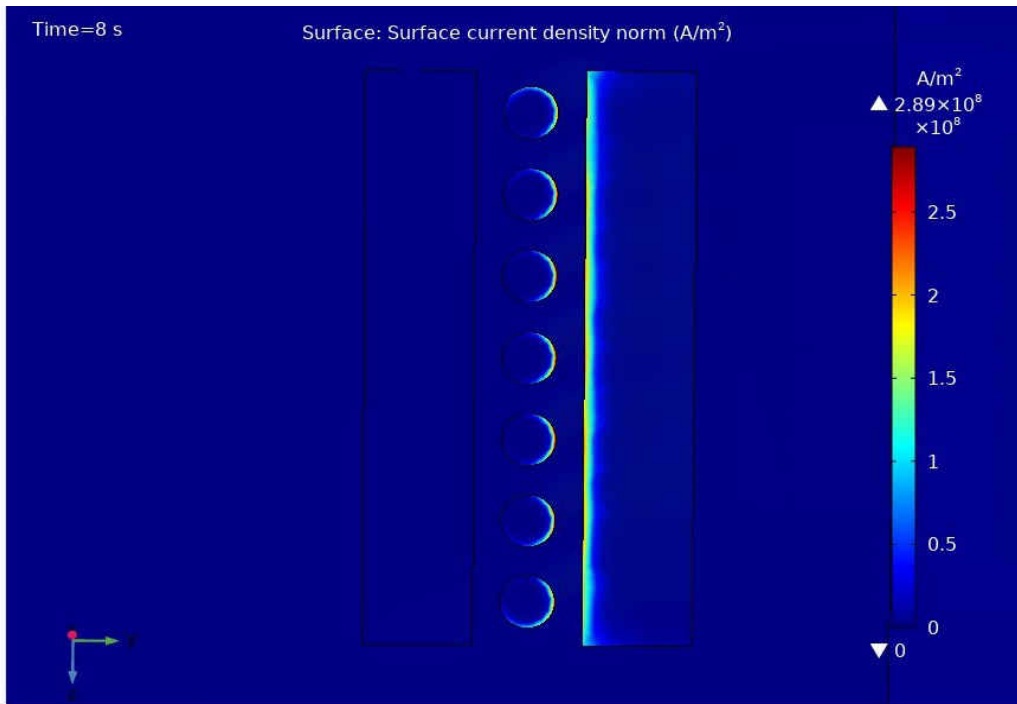

Fig. 13. Representation of current density in inductor and workpiece [elaborated by author]

Figure 14 shows the image of the thermal spectrum of the heater at the 8th second of the heating process of the workpiece.

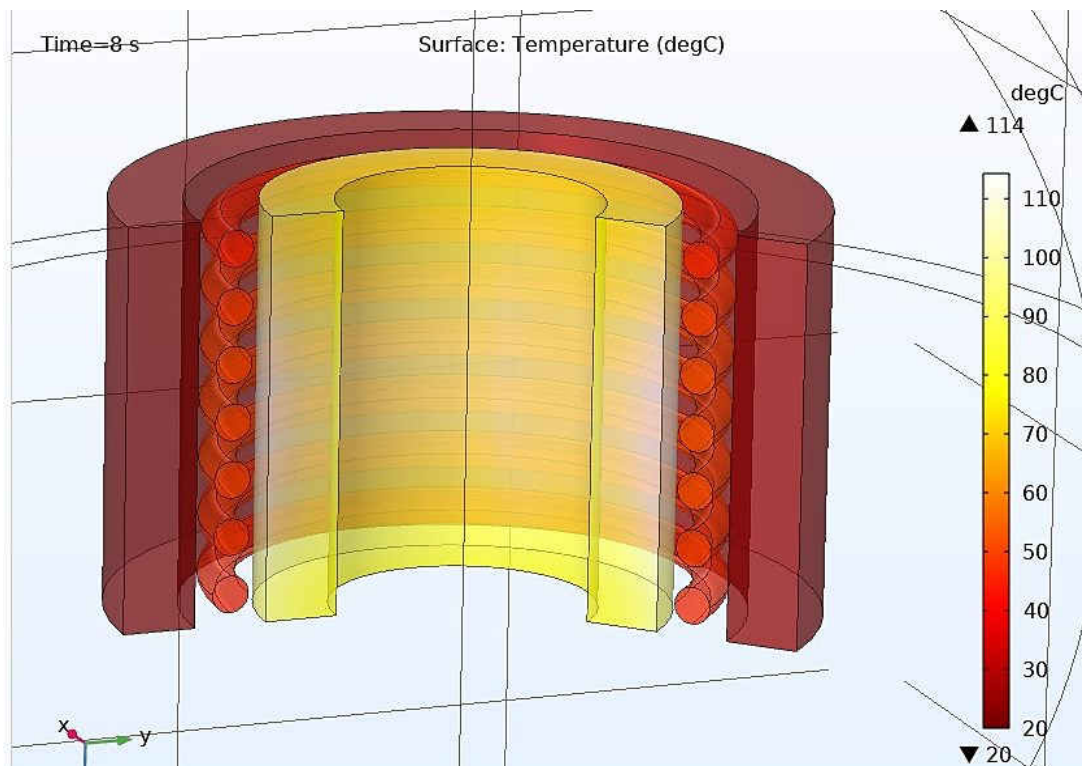

Fig. 14. View in the thermal spectrum of the axial 2D model with the magnetic circuit at the 8th second of the simulation of the preheating process [elaborated by the author]

The simulations demonstrated that feeding the inductor of the heater with a current of 200 A with a frequency of 100 kHz allows the workpiece to be heated up to the calculated surface temperature of the workpiece in 7.6 seconds.

The inclusion of the laminar fluid flow range in the developed model allowed a better understanding of the behavior of water inside the workpiece. **Figure 15** below shows the representation of the variation in water viscosity as it flows through the water channel and inside the workpiece.

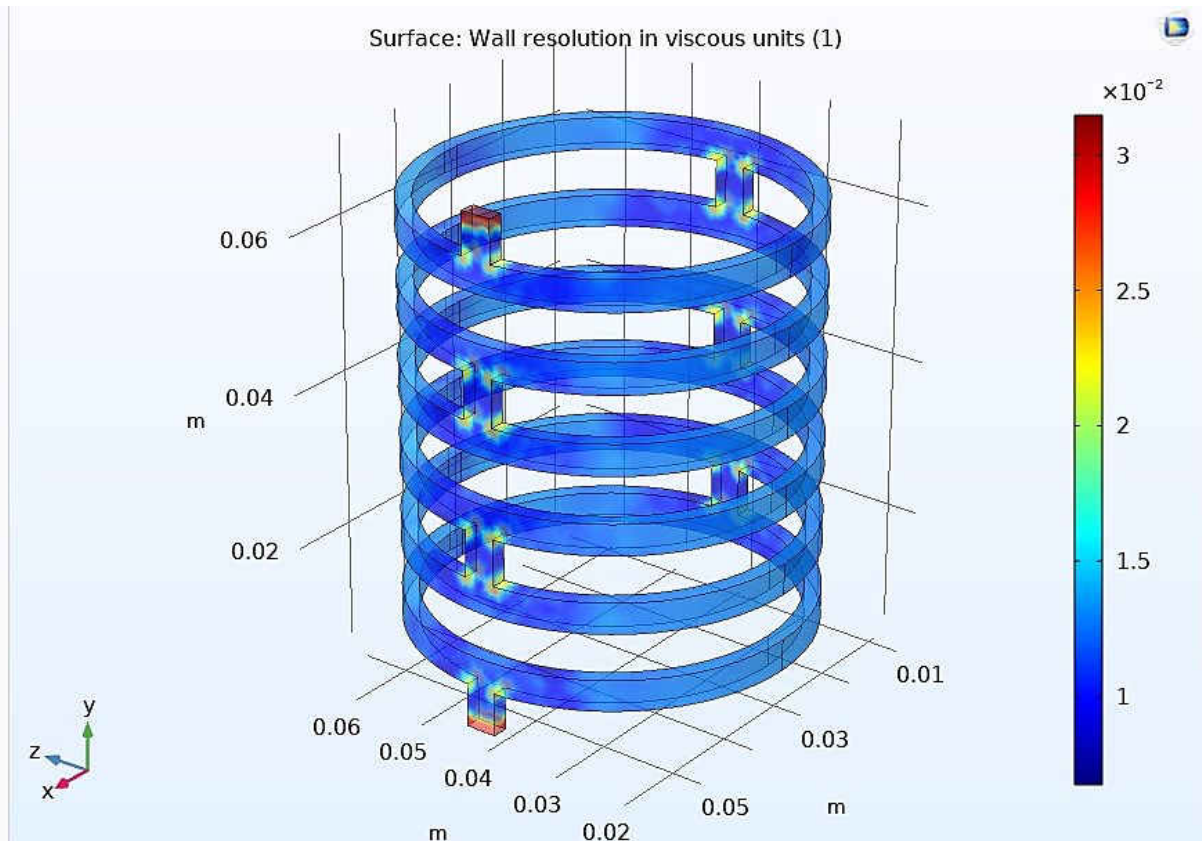

Fig. 15. Representation of water viscosity variation in the channel of the workpiece [elaborated by the author]

The water channel consists of annular channels joined together so that the flow of water is uniform through all sections. The connections between the rings are 90° compared to the horizontal rings of the channel, and on the one hand, they cause the appearance of hydrodynamic resistances in the flow process; on the other hand, they have a positive effect on the heat transfer process, causing turbulence in the flow process.

To automate the grinder adjustment process, it is necessary to adjust the positioning of the abrasive discs and move the upper disc up for coarser grinding and down for finer grinding; it is necessary to move the adjustment ring on the grinder (**figure 16.**) against clockwise for finer sanding and clockwise for coarser grinding. As a reaction signal in the process of adjusting, the signal taken

from the flow meter of the hydraulic system will serve. Figure 17 shows the grinder adjustment ring to enable it to rotate the adjustment ring by means of an additional drive motor.

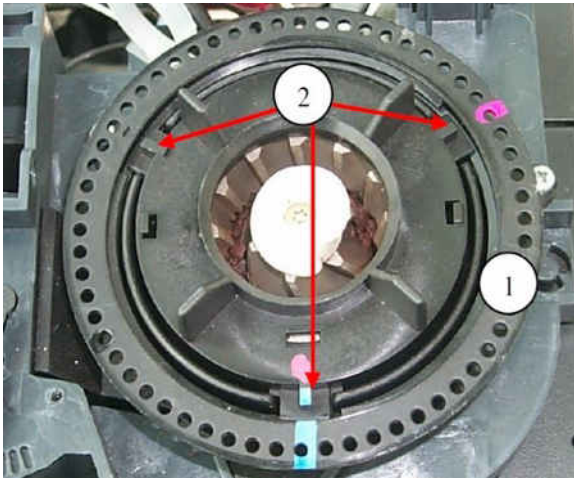

Fig. 16. SAECO grinder
1 – adjustment ring
2 – three fixing rods of the upper grinding disc

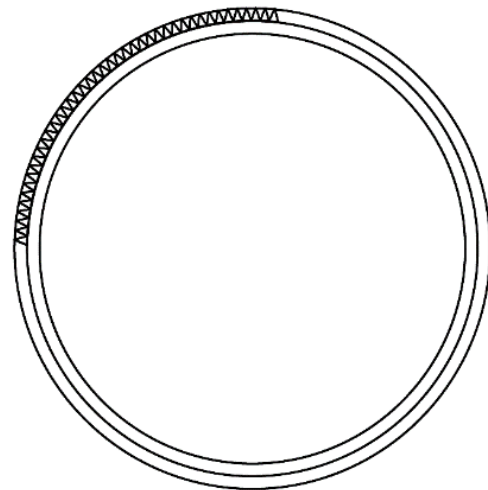

Fig. 17. The gear wheel of the automated adjustment system
[elaborated by the author]

The actual adjustment performed by a technical operator has several steps, which are listed in the following list:

1. Perform the first extraction to check the condition of the grinder.
2. Turn the adjustment ring for just a few degrees in the direction needed for adjustment
3. Make 2-3 draws to check the new adjustment.
4. If other adjustments are necessary, steps 2 and 3 are repeated again, and these actions can be repeated as many times as necessary.

The automatic adjustment system must repeat the steps described above. For this, some changes are made to the grinding system. **Figure 18** shows a structural diagram with the necessary changes.

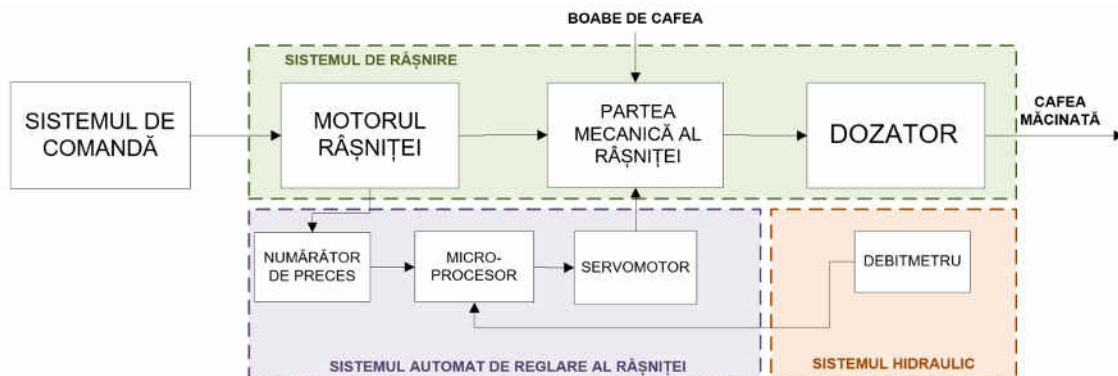

Fig. 18. Diagram of the modernized electromechanical system of the grinder
[elaborated by the author, 30]

The reducer and drive motor model were developed in the MATLAB environment to simulate the grinder adjustment process (Figure 19).

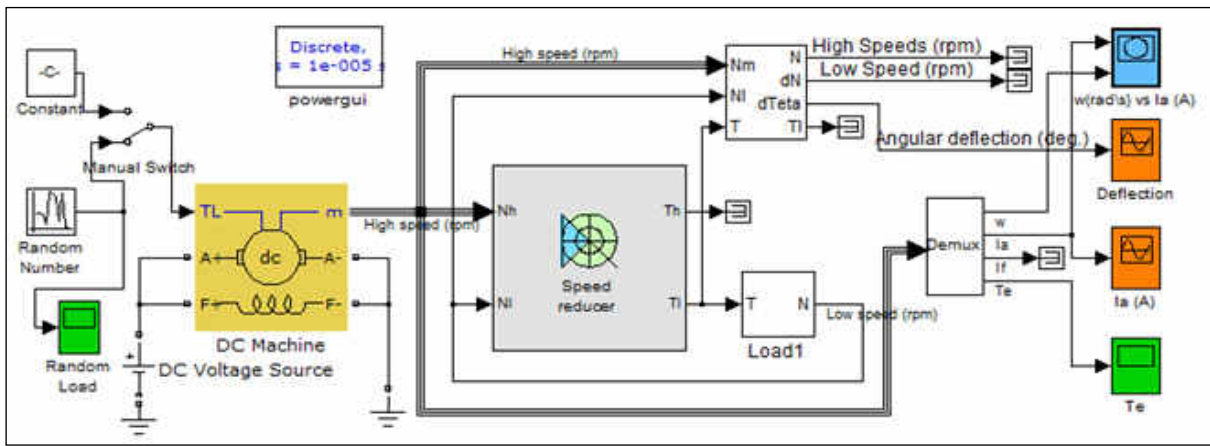

Fig. 19. DC motor speed reducer simulation adjustment system [developed by the author, 53]

After the simulation is performed, the modeling results are displayed according to the magnitudes of the investigated parameters of this model. Representations of the resulting characteristics are shown in **Figure 20** for constant grinder load.

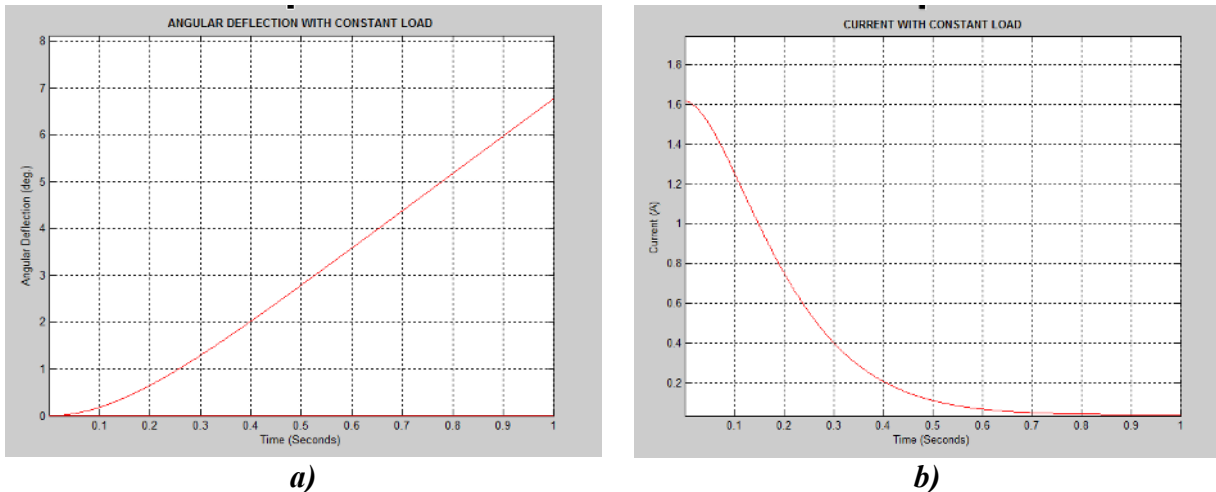

Fig. 20. Results of dc motor speed reducer simulation in SimPowerSystems with constant load: [elaborated by the author, 53]

a – angular deformation of the grinder adjustment ring;

b – armature current of the dc actuator of the regulating system

Figure 21 shows the representation of results for variable load. The simulation showed that even with variable load on the grinder, angular displacement in 1-2 seconds is sufficient for adjustment procedures.

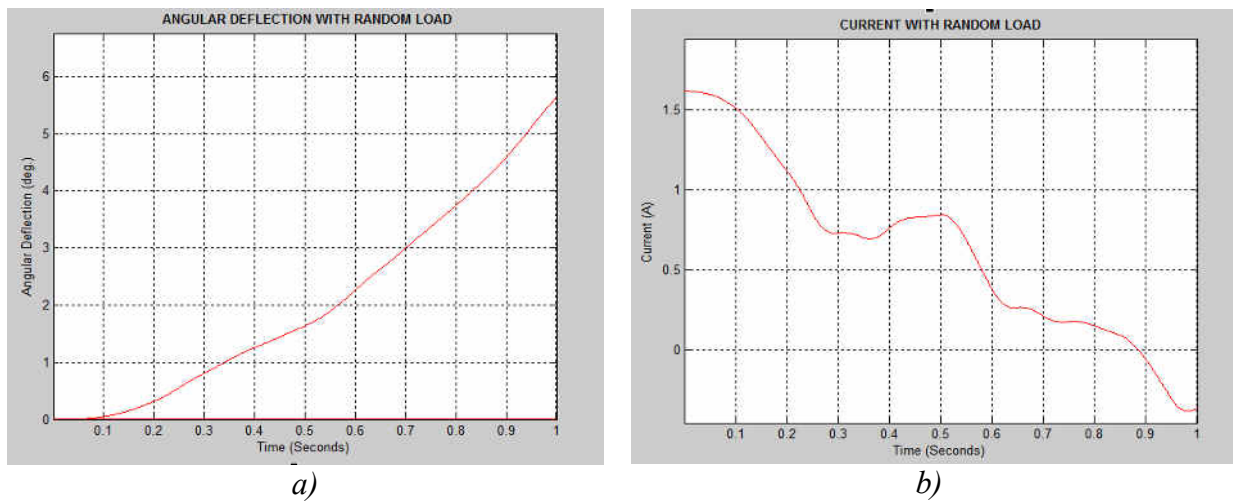

Fig. 21. Results of DC motor speed reducer simulation in SimPowerSystems with random load: [elaborated by the author, 53]
a – angular deformation of the grinder adjustment ring; *b* – armature current of the DC actuator of the regulating system.

The possibility of implementing pumping systems with adjustable speeds was further investigated. **Figure 22** shows the simulation scheme developed in the MatLab Simscape environment for testing the apparatus with a single-phase asynchronous motor and a valve displacement pump with a pressure relief valve generated by the pump.

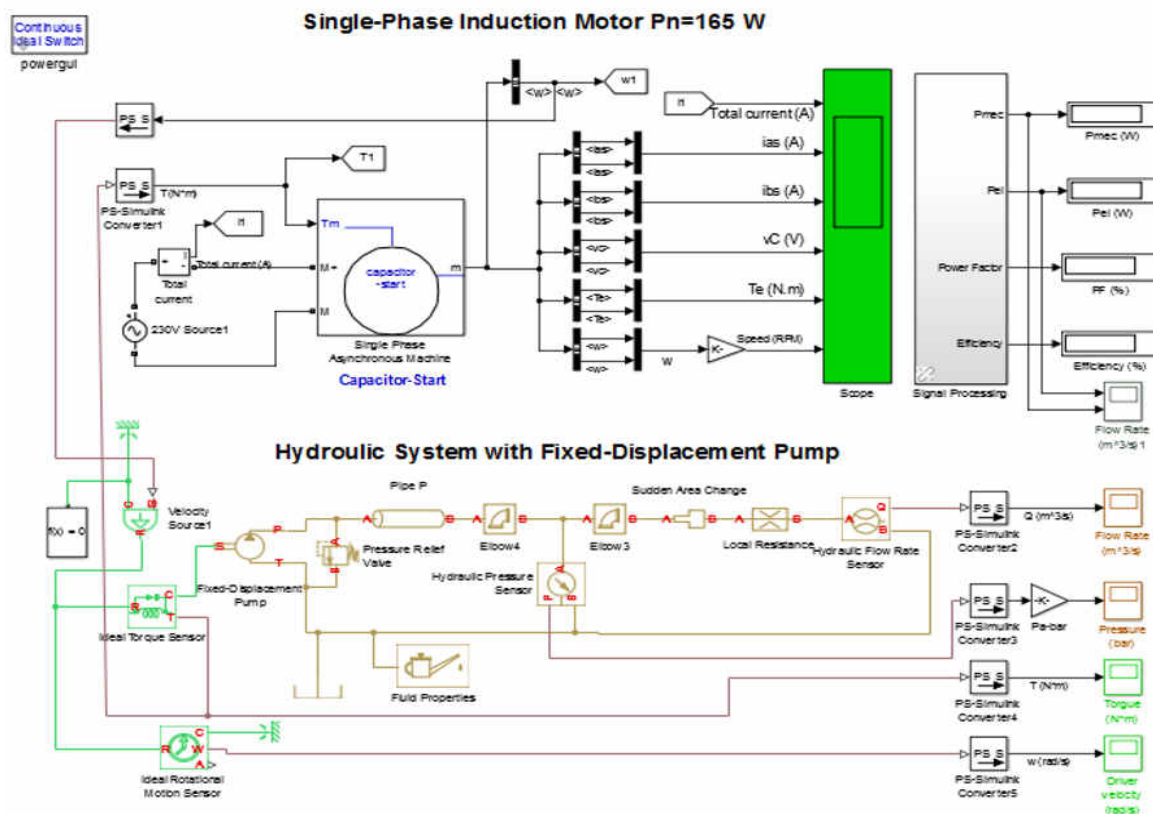

Fig. 22. Simulation diagram of single-phase induction motor with hydraulic load, using Simscape physical signal library [elaborated by the author, 35]

The pump performance is shown in diagrams **Figure 23**, where the pump pressure relief valve cuts through the output parameters to provide the preset values. The use of the valve allows to

maintain the required working parameters well enough, but the engine absorbs about 40% more power than necessary, which diminishes the efficiency of the system.

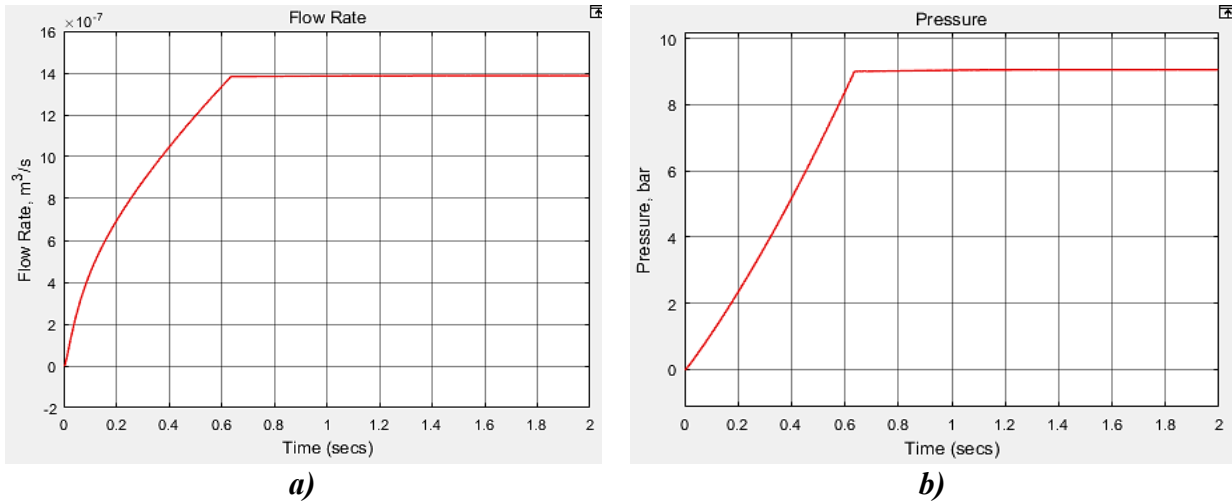

Fig. 23. Performance of the fixed displacement pump [elaborated by the author, 35]:
a - water flow; *b* - pressure inside the pipe before the coffee room.

The electromagnetic pump, the simulation scheme is shown in **figure 24**, creates the flow rate and pressure using the functional principle of a two-cylinder hydraulic differential motor.

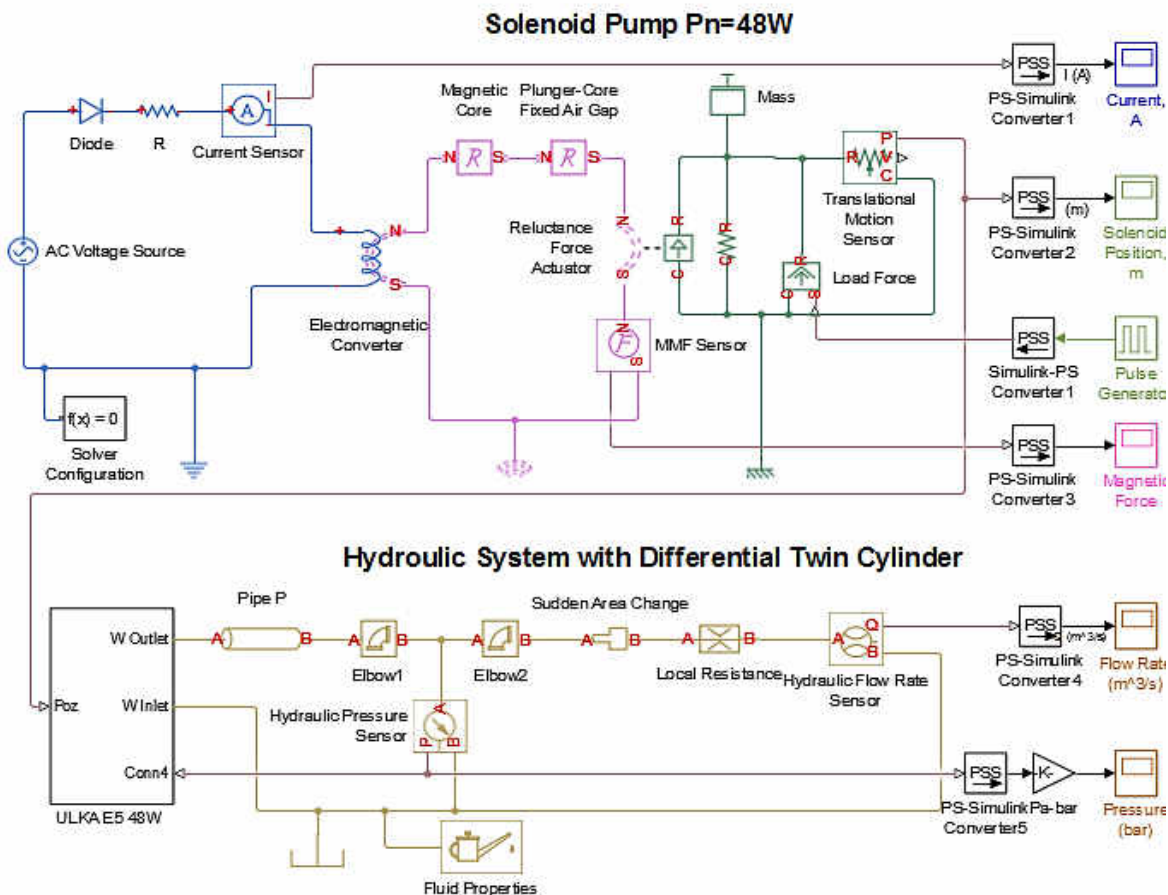

Fig. 24. Simulation diagram of the electromagnetic pump with hydraulic load, using the Simscape physical signal library [elaborated by the author, 35]

Figure 25 shows diagrams obtained for water flow and pressure within the account up to the extraction chamber.

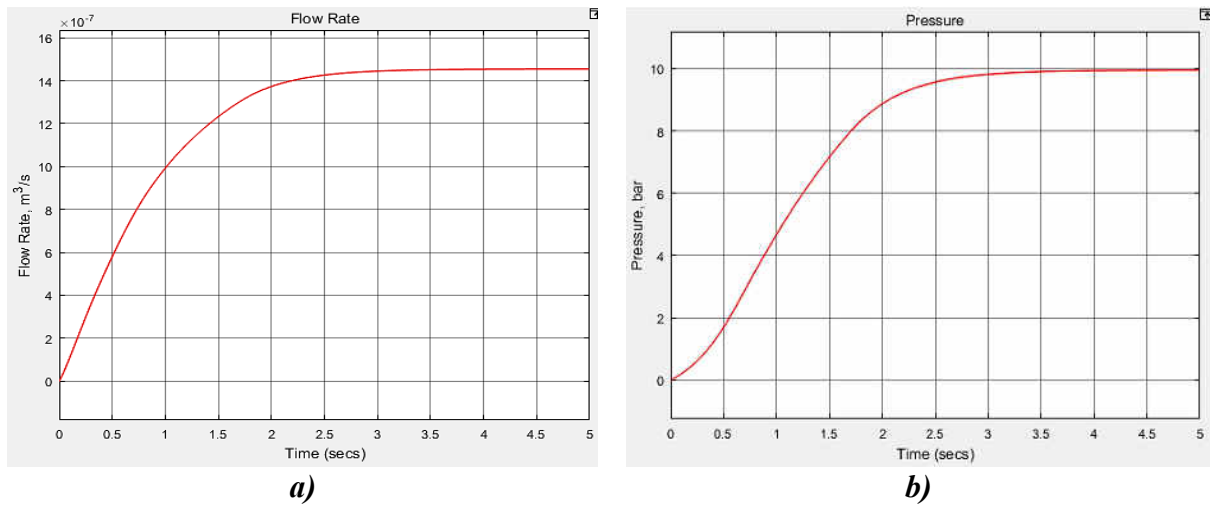

Fig. 25. Performance of ULKA E5pump during extraction [elaborated by the author, 35]:

a - water flow; *b* - pressure inside the pipe before the coffee room

Comparative analysis of the results of the above simulations has shown that using the electromagnetic pump offers several advantages: low energy consumption, the possibility of use in machines with a water tank, and slower pressure increase during extraction creates a beneficial pre-infusion effect of the extracted coffee.

The modeling and simulation of hydraulic systems with electromagnetic pumps developed on the basis of the State-Space model, for which the state-space matrices presented below were deduced, allowed an analysis of the possibilities of implementing variable flow in hydraulic systems of this type.

$$\begin{bmatrix} \delta \dot{x}_1 \\ \delta \dot{x}_2 \\ \delta \dot{x}_3 \\ \delta \dot{x}_4 \end{bmatrix} = \begin{bmatrix} 0 & 1 & 0 & 0 \\ -3,6 \cdot 10^4 & -9,9 \cdot 10^{-6} & -4,3 \cdot 10^5 & 0 \\ 0 & 0,419 & -192,34 & 0 \\ 0 & 1,96 \cdot 10^{-5} & 0 & 0 \end{bmatrix} \cdot \begin{bmatrix} \delta x_1 \\ \delta x_2 \\ \delta x_3 \\ \delta x_4 \end{bmatrix} + \begin{bmatrix} 0 \\ 0 \\ 0 \\ 0 \end{bmatrix} \cdot \delta u$$

$$y = [0 \quad 0 \quad 0 \quad 1] \cdot \begin{bmatrix} \delta x_1 \\ \delta x_2 \\ \delta x_3 \\ \delta x_4 \end{bmatrix} + [0] \cdot \delta u$$

Figure 26 is the schematic representation of the hydraulic circuit created for the purpose of simulation.

HYDRAULIC SYSTEM WITH STATE-SPACE MODEL OF THE Pn=48W SOLENOID PUMP

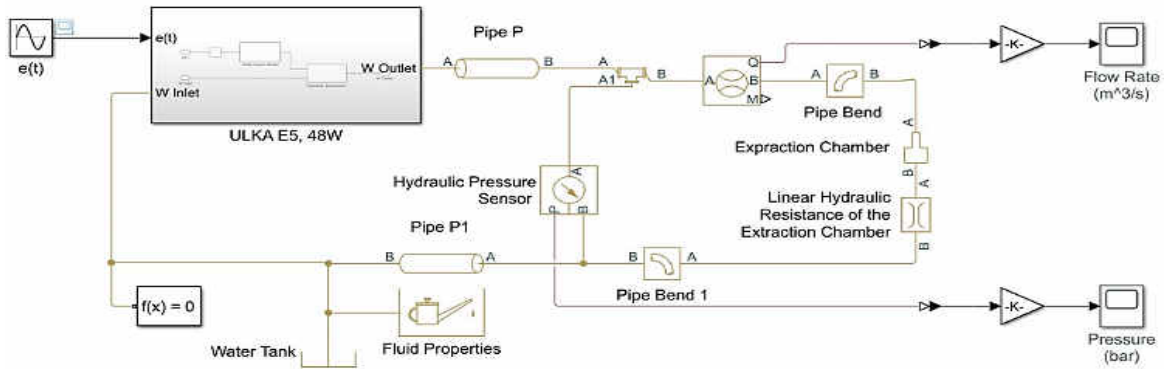

Fig. 26. Scheme of simulation of electromechanical performance of vibrating armature pump [developed by author, 38].

As a result of the simulations performed, the required linear scalar dependence of flow rate and the voltage variation diagram are shown in **figure 27**.

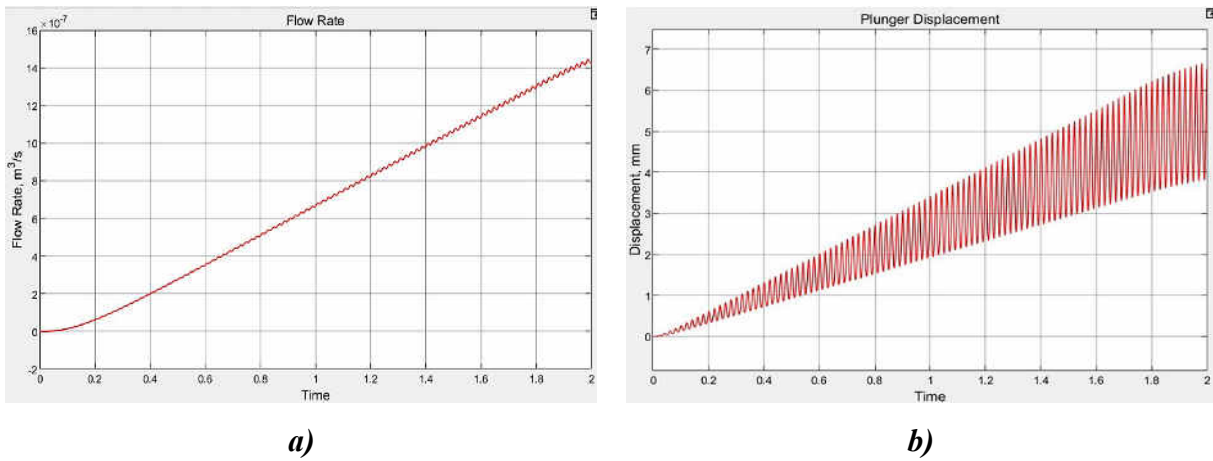

Fig. 27. Performance of variable voltage source pump [elaborated author,38]:
a – liquid flow rate; *b* – piston displacement.

This study concluded that the flow rate of the electromagnetic pump of the construction in question can be regulated by varying the supply voltage rather than the frequency.

The research of the CNC compaction system concluded with a set of parameters of the linear actuator, which are presented in the table below.

Tabelul 2. Linear actuator sizing results

ELEMENTUL	PARAMETRUL
Lead screw speed	0,067 m/s
Angular velocity on lead screw	70,16 rad/s
Torque at lead screw	0,263 Nm
Minimum compaction torque	0,057 Nm
Average compaction torque	0,228 Nm
Maximum compaction torque	0,399 Nm
Current at minimum settlement torque	1,32 A
Medium settlement torque current	2,78 A
Current at maximum compaction torque	4,24 A

Figure 28 shows the distance of movement of the load. Since the load torque is much lower than the nominal torque of the actuator, the effect of the load on the lead screw and the compaction process is not visible, so the travel speed is constant and linear.

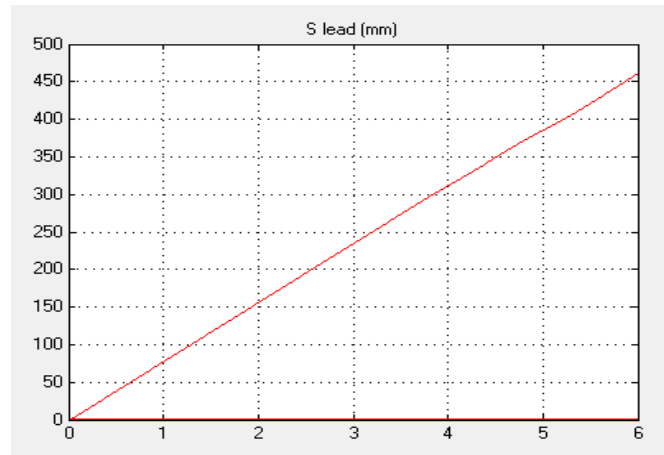

Fig. 28. Representation of the distance of movement of the load [elaborated by the author]

The final results of the simulation show that the dimensioned linear actuator will move the load from the downward to a closed position in less than 3 seconds, and the referential range of adjustment currents for controlling the compaction force will constitute $I_{ad} = 1,7 \div 4,2 A$.

At the end of the chapter, the analysis of the impact of innovations on the performance parameters of the coffee machine was carried out, which was divided into three parts:

- *Determination of energy losses in the operation of resistive boilers* – the resistive heater consumes a power of about 29% more than is required for the components subjected to heating, which proves that throughout the lifetime of the boiler of this type the energy consumption will be even higher;
- *Comparative analysis of energy consumption between resistive and inductive heater* – the implementation of the inductive heater at itinerant coffee drink trading points will increase the energy efficiency of appliances by over 55%;
- *Analysis of the impact of innovations on the quality indicators of the grinding system* – the results obtained in the X-bar diagrams demonstrate that adjusting the grinder with the help of the automatic system maintains the optimal parameters of coffee density in the extraction chamber with an average of $537 \text{ kg} / \text{m}^3$, while in the manual adjustment system this value is $598 \text{ kg} / \text{m}^3$ at the same time, R-charts show a qualitative improvement in samples in each subgroup demonstrating a decrease in variation in each subgroup by almost half, from 58 to 32 units.

GENERAL CONCLUSIONS AND RECOMMENDATIONS

1. The topicality of the thesis topic is conditioned by the need to develop and implement integrated electromechanical systems to increase the quality of the finished product and the energy efficiency of automated coffee machines in the context of current eco-design policies.

2. The flow diagram of the technological process, made as a result of research (chapter 1, paragraph 1.1), has demonstrated that the physicochemical properties and quality of coffee beans, reached at the extraction stage of the beverage is influenced both by a multitude of factors and parameters of numerous technological processing processes, as well as by the quality of their realization, which conditions the need for adjustable electromechanical systems of technological installations in extraction of coffee drinks.

3. Based on the study of the impact of the environment on the performance of electromechanical systems of coffee machines (Chapter 1, paragraph 1.1) with the use of statistical methods and software, very strong correlations of $r = 0,96$ between the weight of ground coffee of the filled container and the humidity of the external environment were demonstrated and shows a directly proportional relationship and $r = - 0,95$ between the flow rate for a filled container and the humidity of the external environment vice versa proportional.

4. The flow diagram of the coffee machine's operating process has been developed (Chapter 3, paragraph 3.1) with the addition of inductive heater to water treatment functions, extraction process data collection blocks, automatic grinder adjustment, automatic burring/compaction adjustment and change of grinder setting to coffee bean processing functions.

5. In Chapter 3, paragraph 3.2 was developed the 3D and 2D Axial model of the innovative inductive heater developed and dimensioned in COMSOL MULTIPHISICS software demonstrated that the developed inductive heater ensures the operation process of the coffee maker, powered with a current of 200A at a frequency of 100 kHz, with an efficiency of over 55%, inductive heater pre-heating only 7.6 seconds versus 90 seconds with resistive heater.

6. Numerical analysis in the state space and simulations in MatLab Simscape of the peculiarities of flow regulation in systems with electromagnetic pumps (Chapter 3, paragraphs 3.1 and 3.2) demonstrated that the frequency variation is directly proportional to the frequency of displacement of the pump piston and the variation of current is directly proportional and linear to the piston travel distance, therefore, with the flow rate.

7. The numerically controlled electromechanical system for automatic grinder adjustment (Chapter 3, paragraphs 3.1 and 3.2) provides the required angular displacement of the grinder adjustment ring.

8. The compaction system, with elaborate numerical control, covers the distance of 0.2 meters of the preparation unit in less than 3 seconds, with the limits of the rotor current of the linear servo motor implemented for automatic numerical control between 1.7÷4.2 A.

9. In Chapter 3, paragraph 3.3 it was studied the impact of innovations on the performance parameters of the coffee machine where the comparative analysis of energy consumption between conventional resistive heater and innovative inductive heater demonstrated an increase in energy efficiency of over 55%, completely eliminating the time required for the pre-heating process and maintaining the machine at working parameters;

10. The analysis of innovations' impact on the grinding system's performance indicators carried out in the STATISTICA software (chapter 3, paragraph 3.3) demonstrated the complete elimination of the external environment's impact on the grinding process, maintaining the performance indicators at optimal parameters.

Recommendations:

- Proposals for use:
 - The mathematical model of the electromagnetic pump made in the state space and its model made in MatLab Simscape can be used in various research with the implementation of this type of pump;
 - The designed and patented inductive heater can be adapted and used in various systems;
- Suggestions on potential research directions:
 - Research of stainless steel implementation methods for the manufacture of inductive heater workpieces taking into account the properties of this type of steel;
 - Redesign of the coffee machine's hydraulic system using the inductive heater to use the internal cylinder space of the workpiece as an extraction chamber, thus improving the efficiency and quality of extraction. Implementation of numerical control of the entire espresso extraction process.

LIST OF AUTHOR'S PUBLICATIONS ON THE TOPIC OF THE THESIS

Articles in scientific journals

Articles in magazines abroad

- **ȚURCANU, Adrian** NUCA, Ilie,. Modernization of the Grinding Electromechanical Drive System of the Automated Coffee Machine. Proceedings of the 17th National Conference on Electrical Drives "CNAE 2014". Reșița, 09-10 octombrie 2014. Analele Universității "Eftimie Murgu" . Anul XXL, nr.2, p.251-262. ISSN 1453-7397
- I Nuca1 , T Ambros , M Burduniuc , S I Deaconu and **A Turcanu**. Electric machines with axial magnetic flux. IOP Conf. Series: Materials Science and Engineering 294 (2017) 012059. ISSN: 1757899X 17578981 <http://iopscience.iop.org/article/10.1088/1757-899X/294/1/012059/meta>

Articles in journals from the National Register of Profile Journals (cat. B+)

- **ȚURCANU, Adrian** NUCA, Ilie,. Implementation Of Inductive Processes In General-Purpose Equipment To Streamline Heat Transfer Processes. In: Journal of Engineering Sciences. ISSN 2587-3474 / E-ISSN 2587-3482 (in curs de editare).

Articles in scientific collections

Articles in the proceedings of international scientific conferences with indexing in BDI Web of Science and SCOPUS:

- **ȚURCANU, Adrian**, NUCA, Ilie, MAKAL, Jaroslaw. Numerical analysis of the peculiarities of flow rate adjustment in armature vibrating pump in hydraulic systems applications. In: *Mechatronic Systems and Materials MSM 2020*. Ediția a 15-a, 1-3 iulie 2020, Bialystok. Piscataway, ISBN 978-172816956-9. <http://www.scopus.com/inward/record.url?eid=2-s2.0-85094211242&partnerID=MN8TOARS> , <https://publons.com/wos-op/publon/65418102/>
- LUCACHE, Georgiana, **ȚURCANU, Adrian**, LUCACHE, Dorin, NUCA, Ilie. Comparative study of the level of awareness of E-waste management in Romania and Republic of Moldova. In: *Sielmen Proceedings of the 11th international conference on electromechanical and power systems*. Ediția 11, 11-13 octombrie 2017, Iași. ISBN 978-153861846-2. <http://www.scopus.com/inward/record.url?eid=2-s2.0-85043492824&partnerID=MN8TOARS>
- **ȚURCANU, Adrian**. Comparative study of the vibrating armature and rotary vane pumps. In: *Sielmen Proceedings of the 11th international conference on electromechanical and power systems*. Ediția 11, 11-13 octombrie 2017, Iași. New Jersey, SUA: Institute of Electrical and Electronics Engineers Inc., 2017, pp. 94-99. ISBN 978-153861846-2. <http://www.scopus.com/inward/record.url?eid=2-s2.0-85043521292&partnerID=MN8TOARS> , <https://publons.com/wos-op/publon/65418103/>

- **ȚURCANU, Adrian**, NUCA, Ilie. Implementation of the automatically adjustable tamping process in the automated coffee brewing. In: *Conference on Applied and Theoretical Electricity ICATE 2016*. 6-8 octombrie 2016, Craiova. New Jersey, SUA: Institute of Electrical and Electronics Engineers Inc., 2016, p. 0. ISBN 978-146738562-6. DOI: <http://www.scopus.com/inward/record.url?eid=2-s2.0-85006758087&partnerID=MN8TOARS>, <https://publons.com/wos-op/publon/65418104/>

Articles in other collections of scientific papers published in the Republic of Moldova

- **ȚURCANU, Adrian**. Metode de eficientizare al proceselor tehnologice în instalații usuale. In: *Conferința tehnico-științifică a studenților, masteranzilor și doctoranzilor*. Vol.1, 26-29 martie 2019, Chișinău. Chișinău, Republica Moldova: 2019, pp. 111-114. ISBN 978-9975-45-588-6. https://ibn.idsi.md/vizualizare_articol/84322
- **ȚURCANU, Adrian**, NUCA, Ilie. Utilizarea tehnologiilor informaționale in analiza și controlul calității procesului de producție a cafelei „Espresso”. In: *Telecommunications, Electronics and Informatics*. Ed. 5, 20-23 mai 2015, Chișinău. Chișinău, Republica Moldova: 2015, pp. 111-113. ISBN 978-9975-45-377-6. https://ibn.idsi.md/vizualizare_articol/62250
- **ȚURCANU, Adrian**. Electrical actuation of the grinder of an automated coffee. In: *Conferința Tehnico-Științifică a Colaboratorilor, Doctoranzilor și Studenților consacrată celei de-a 50-a Aniversări a U.T.M.*. Vol.1, 20-21 octombrie 2014, Chișinău. Chișinău, Republica Moldova: Tehnica-UTM, 2014, pp. 515-522. ISBN 978-9975-45-249-6. https://ibn.idsi.md/vizualizare_articol/181437

Patents for inventions and other intellectual property objects (IPOs), materials at exhibitions

- **ȚURCANU, Adrian**. *Încălzitor inductiv*. Brevet de invenție de scurtă durată 1617. Nr. depozitului s 2020 0005. Data depozitului 03.02.2020. Publicat 30.04.2022. In: BOPI. nr. 4, 2022 <http://www.db.agepi.md/Inventions/details/s%202020%200005>

ADNOTARI

Autor – ȚURCANU Adrian. **Titlul** – *Sisteme electromecanice integrate cu control numeric pentru aparate de cafea*. Teză de doctor pentru conferirea titlului de doctor în științe tehnice la specialitatea 222.01 – *Dispozitive și echipamente electrotehnice*: Chișinău 2024

Structura tezei: Lucrarea conține introducerea, trei capitole, concluzii generale și recomandări, bibliografie din 110 titluri, 16 anexe, 179 pagini, 125 de figuri și 31 de tabele. Rezultatele obținute sunt publicate în 8 lucrări științifice și 1 brevet de invenție.

Cuvinte cheie: aparat de cafea, sistem electromecanic, încălzitor inductiv, control numeric, modelare matematică, control statistic, matlab simscape, comsol multiphysics.

Scopul lucrării: Dezvoltarea și implementarea sistemelor electromecanice (SEM) integrate avansate pentru majorarea calității produsului finit și a eficienței energetice în aparatele de cafea.

Obiectivele lucrării: analiza și identificarea problemelor ingineresti în funcționarea echipamentelor tehnologice în industria cafelei, elaborarea conceptelor constructiv-funcționale inovaționale ai SEM pentru automatele de cafea, implementarea noilor metode și procedee în SEM ale aparatelor de cafea.

Noutatea și originalitatea științifică a lucrării constă în delimitarea problemelor și identificarea căilor posibile de creștere a eficienței de funcționare și a calității produsului finit prin implementarea soluțiilor tehnico-științifice avansate ai SEM integrate pentru aparatele de cafea, inclusiv soluții brevetate.

Problema științifică importantă soluționată se demonstrează prin reducerea impactului negativ al factorilor exogeni și endogeni asupra calității produsului finit, prin dezvoltarea și implementarea SEM integrate, bazate pe algoritmi de comandă numerici, prin sporirea eficienței energetice a aparatelor de cafea.

Importanța teoretică a lucrării relevă din noile abordări teoretico-practice privind implementarea metodelor și procedeele tehnologice în SEM avansate cu control numeric pentru aparate de cafea.

Valoarea aplicativă a lucrării. Au fost realizate soluții tehnice importante în procesul de modernizare al instalației tehnologice, pentru aparate de cafea, ce includ sisteme electromecanice integrate cu control numeric și realizează reglarea automată a parametrilor procesului de producție. Astfel, se asigură calitatea înaltă a produsului finit, prin diminuarea influenței factorilor externi și sporirea semnificativă a eficienței energetice.

Implementarea rezultatelor științifice ale tezei: încălzitorul inductiv în cadrul *M-Consulting SRL*; reglarea automată a râșniței *Coffee Hub SRL*; controlul numeric al tasării *Coffee Planet Group SRL*.

ABSTRACT

Author – ȚURCANU Adrian. **Title** – *Integrated electromechanical systems with numerical control for coffee machines*. Ph.D. thesis for conferring the scientific title of doctor of technical sciences in specialty 222.01 – *Electrotechnical devices and equipment*: Chisinau 2024

Thesis structure: The paper contains an introduction, three chapters, general conclusions and recommendations, a bibliography of 110 titles, 14 annexes, 185 pages, 139 figures, and 31 tables. The obtained results are published in 8 scientific papers and 1 patent.

Keywords: coffee machine, electromechanical systems, inductive heater, numerical control, mathematical modeling, statistical control, Matlab simscape, comsol multiphysics.

The purpose of the work: Development and implementation of advanced integrated electromechanical systems to increase the quality of the finished product and energy efficiency for coffee machines.

Objectives of the work: analysis and identification of engineering problems in the operation of technological equipment in the coffee industry, elaboration of innovative constructive-functional concepts of SEM for coffee machines, implementation of new methods and processes in SEM of coffee machines.

The scientific novelty and originality of the work consist of delimiting problems and identifying solutions to increase the operating efficiency and quality of the finished product by implementing advanced technical-scientific solutions of integrated SEM for coffee machines.

The important scientific problem solved is demonstrated by reducing the negative impact of exogenous and endogenous factors on the quality of the finished product, developing and implementing integrated SEM based on numerical control algorithms, and increasing coffee machines' energy efficiency.

The theoretical importance of the paper is revealed by the new theoretical-practical approaches regarding the implementation of technological methods and procedures in advanced SEM with numerical control for coffee machines.

Applicative value of the work. Important technical solutions have been achieved in the process of modernization of the technological installation for coffee machines, which include integrated electromechanical systems with numerical control and perform automatic adjustment of the parameters of the production process. Thus, the high quality of the finished product is ensured by reducing the influence of external factors and significantly increasing efficiency.

Implementation of the scientific results of the thesis: inductive heater within *M-Consulting SRL*; automatic adjustment of the grinder *Coffee Hub SRL*; numerical control of settlement *Coffee Planet Group SRL*.

РЕЗЮМЕ

Автор – ЦУРКАНУ Адриан. **Название** – *Интегрированные электромеханические системы с числовым программным управлением для кофемашин*. Кандидатская диссертация на соискание ученого звания доктора технических наук по специальности 222.01 – *Электротехнические устройства и оборудование*: Кишинев 2024

Структура диссертации: Работа содержит введение, три главы, общие выводы и рекомендации, библиографию из 110 наименований, 16 приложений, 179 страниц, 125 рисунков, 31 таблиц. Результаты опубликованы в 8 научных работах и 1 патенте.

Ключевые слова: кофемашина, электромеханические системы, индукционный нагреватель, числовое управление, математическое моделирование, статистическое управление, matlab simscape, comsol multiphysics.

Цель работы: Разработка и внедрение перспективных интегрированных электромеханических систем (ЭМС) для повышения качества готовой продукции и энергоэффективности кофемашин.

Задачи диссертации: анализ и выявление инженерных проблем при эксплуатации технологического оборудования в кофейной промышленности, разработка инновационных конструктивно-функциональных концепций ЭМС для кофемашин, внедрение новых методов и процессов в ЭМС кофемашин.

Научная новизна и оригинальность работы заключается в разграничении проблем и определении возможных путей повышения эффективности работы и качества готового продукта за счет внедрения передовых научно-технических решений в ЭМС для кофемашин.

Важная решенная научная проблема за счет снижения негативного влияния экзогенных и эндогенных факторов на качество готовой продукции, разработки и внедрения интегрированных ЭМС на основе алгоритмов числового программного управления, за счет повышения энергоэффективности кофемашин.

Теоретическая значимость работы раскрывается новыми теоретико-практическими подходами к реализации технологических методов и процедур в перспективных ЭМС с числовым программным управлением для кофемашин.

Практическая значимость работы. Важные технические решения были достигнуты в процессе модернизации технологической установки кофемашин, которые включают в себя интегрированные электромеханические системы с числовым программным управлением и выполняют автоматическую регулировку параметров производственного процесса. Таким образом, высокое качество готового продукта обеспечивается за счет снижения влияния внешних факторов и значительного повышения энергоэффективности.

Внедрение научных результатов диссертации: индукционный нагреватель в *M-Consulting SRL*; автоматическая регулировка кофемолки *Coffee Hub SRL*; *числовое программное управление расчетом Coffee Planet Group SRL*.

TURCANU ADRIAN

**INTEGRATED ELECTROMECHANICAL SYSTEMS WITH
NUMERICAL CONTROL FOR COFFEE MACHINES**

222.01- ELECTROTECHNICAL DEVICES AND EQUIPMENT

Summary of the thesis of doctor of engineering sciences

Approved for printing: 20.06.2024

Paper size 60x84 1/16

Offset paper. Offset pattern.

Tiraj 40 ex.

Printing sheets: 2.75

Comanda nr. 86/24

MD-2004, Chişinău, bd. Ştefan cel Mare şi Sfânt, 168. UTM

MD-2045, Chişinău, str. Studenţilor, 9/9. Editura "Tehnica-UTM"

© A. Ţurcanu, 2024