



PARTICULARITIES OF TRIBOLOGICAL BEHAVIOR OF THE CONTACT ELEMENTS OF THE PRECESSIONAL GEAR, MADE OF METALLIC AND PLASTIC MATERIALS

Ion Bostan, Petru Stoicev, Gheorghe Poștaru, Alexandru Buga, Ion Bodnariuc, Andrei Poștaru, Andrei Platon

Technical University of Moldova, Faculty of Mechanical, Industrial and Transport Engineering,
Studentilor str., No. 9/8, MD-2020, Chisinau, Republic of Moldova

Corresponding author: Stoicev Petru, petru.stoicev@imi.utm.md

Abstract: For the first time, the gear contacts of the precessional transmission $A_{(CX-CV)}^{(D,\beta)}$ were subjected to experimental research, on tribomodels, using metallic (steel 40Cr) and polymeric (POM) material couplings in various combinations: steel 40Cr/steel 40Cr, POM/POM and POM/steel 40Cr. The experiments were carried out in conditions without contact lubrication and lubrication (MULTIS EP2). The samples - model, in the form of cylindrical rollers were manufactured from tested materials, with the dimensions established from the conditions of ensuring the geometric and kinematic equivalence of the contact of the precessional gear. The research methodology consists in the loading of the contact in steps with the normal force (F_n) for periods of time determined by the stabilization of the tribological characteristics, especially the temperature T generated by the friction process. The tribological behavior of the contact was determined by the evolutions in time of: the frictional torque (M_f), the temperature in the contact area (T), the friction force (F_{fr}) and the summary friction coefficient (f_{Σ}). The purpose of the research was to experimentally establish the influence of the geometry and kinematics of the contact on the friction process and the tribological behavior of the couplings of materials under study, in the operating conditions of the contact without lubrication and with lubrication. The results of testing on tribomodels, according to the methodology proposed by experimental research, can be successfully applied to the design stage of Precessional Transmission (PT) gears. **Key words:** precessional transmission, tribomodel, lubrication, sliding velocity, summary friction coefficient, normal load force, friction force, frictional torque, sliding friction, rolling friction.

1. INTRODUCTION

The transmission with precessional motion of the satellite, first proposed and patented by the first author of this paper, appeared as a result of the search for a solution to a fundamental problem such as - combining in a single mechanical transmission three performances: extended kinematic possibilities, high bearing capacity and minimal energy losses. These aspects of the problem in question dominated in all objectives throughout the research and development of precessional transmissions (PT), the answer being determined by the following very conclusive and important findings in the field of research [1-4]:

- the expansion of the kinematic possibilities resides in the K-H-V and 2K-H type structures themselves, which by the range of retailed transmission ratios have no analogue among known mechanical transmissions [1];
- increase in bearing capacity of the gears A^B with bolts is due to the multiplicity of gearing with up to 100% pairs of teeth, simultaneously engaged, and of gears A^D (with straight teeth) and $A^{D,\beta}$ (with inclined teeth) – the multiple pair „convex-concave” contact geometry of the teeth, with little difference in radii of curvature [2];
- the increase in the mechanical efficiency of the TP due to the reduction of the relative sliding friction between the conjugated flanks, the improvement of the lubrication conditions by creating interdental cavities for the accumulation of lubricant, including by increasing their rolling rate due to the spherospacial motion of the satellite [3].

As mentioned in [2, 5], to realize the special importance of these three performances, it is enough to perceive the dimensions of economic efficiency, obtained only from the reduction of energy losses in mechanical transmissions. If we consider that 80% of the global energy is transmitted to the driving mechanisms of the cars through mechanical transmissions, then increasing their mechanical efficiency by just 1% will lead to saving 0.8% of the energy produced globally.”

It is well known that any constructive-functional and kinematic design of a gear begins with the correct selection of materials (elements), as well as the lubrication medium.

One of the main reasons why it is necessary to study the contact problems of mechanical gear transmissions is the loss of bearing capacity due to wear and damage to the conjugated surfaces of the teeth. Wear, as a complex tribological phenomenon of contact processes (mechanical, thermal, chemical), without a well-established theory, must be studied through its evolution in the totality of all aspects.

From this point of view, it was proposed to carry out an extensive research of the PT gear (fig. 1), from a tribological aspect, taking into account the geometrical particularities of the tooth profiles and the kinematics of the relative motion of the contact surfaces. The geometry of the profile of the conjugated teeth is determined by the basic constructive parameters of the gear $\delta, \theta, \beta, Z_g, Z_g - Z_b \pm 1$, which allows different shapes and curves of the contact. One of the essential particularities of this gear consists in maintaining constant radii of curvature r of the profiles of the teeth of the satellite and variable radii of curvature ρ_{ki} of the profiles of the teeth of the central wheels. It allows obtaining gears with a small difference in radii of curvature $\rho_{ki} - r$, convex-concave shape of the contact, multiplicity in the gear and relatively low sliding velocities V_{al} . When the constructive parameters vary, the geometry of the contact can be changed and, as a consequence, optimal values of the radii of curvature can be obtained from a tribological point of view.

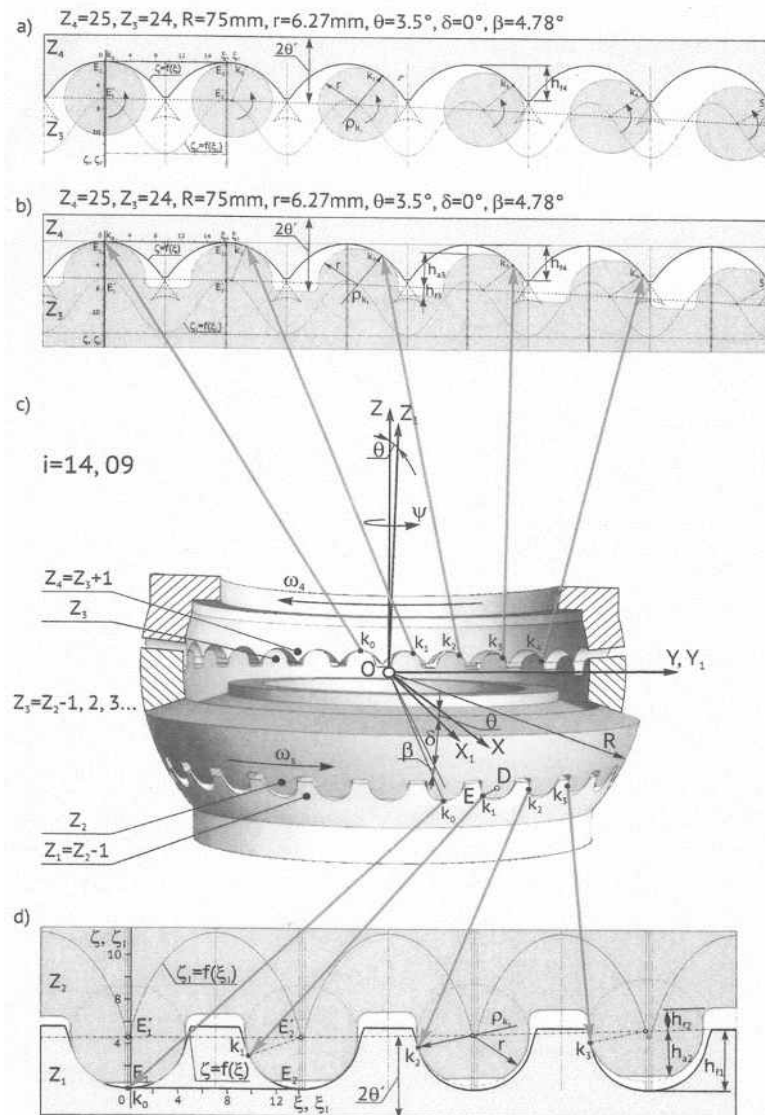

Fig. 1. Precessional gear 2K-H with convex-concave contact shape and reduced relative sliding velocity: a, c, d – gearing of teeth (Z_3-Z_4) and (Z_1-Z_2); b- gearing of toothed wheels with sphero-spatial motion [1-5]

A variant of the precessional gear „immobile central wheel Z_1 - satellite Z_2 ” with concrete values of the constructive parameters $\delta, \theta, \beta, Z_g, Z_g - Z_b \pm 1$, subjected to tribomodelling [7], is presented in (fig.2) where the values of the geometric parameters of the conjugated tooth profiles ($\rho_{ki}, r, \rho_{ki} - r$), the peripheral and sliding velocities ($V_{E_1}, V_{E_{12}}, V_{a_i}$) for each position of the k_i points are obtained when the contact moves on the tooth profiles, depending on the rotation angle Ψ_{ki} of the crank shaft.

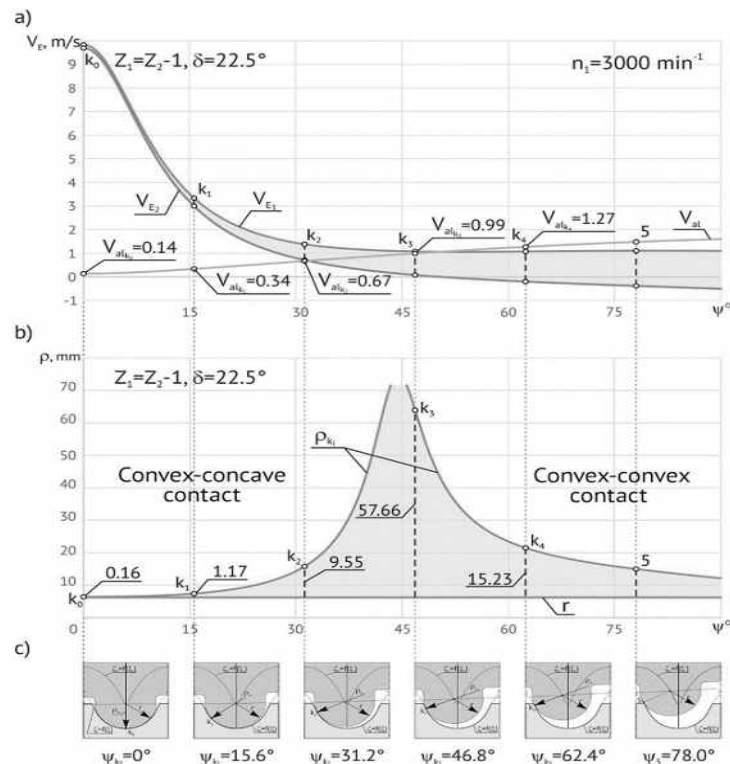

Fig. 2. Peripheral and sliding velocities linear (V_{E1} , V_{E2}) and sliding (V_{sl}) velocities at the contact point (a) and the difference in the radii of curvature ($\rho_{ki} - r$) (b) of the conjugated tooth profiles (c) for the positions k_i of the contact depending on the angle of rotation ψ of the crank shaft. The values of the constructive parameters: $Z_1 = Z_2 - 1$ and $\delta = 22,5^\circ$ ($Z_1 = 24$, $Z_2 = 25$, $\theta = 3,5^\circ$, $\delta = 22,5^\circ$, $r = 6, 27 \text{ mm}$, $R = 75 \text{ mm}$)

Taking into account the complicated geometry and kinematics of the gear in the area of the contact point, in order to ensure an operating capacity established by the design load and with minimal energy losses (maximum efficiency), complex researches in the field of tribological behavior are required. The purpose of these researches is reduced to: 1 - the experimental justification of the chosen material couplings and the lubrication conditions; 2 - establishing, for the concrete version of the designed gear, the values of the constructive parameters (δ , θ , β , Z_b , $Z_g = Z_b \pm 1$), to obtain the geometry of the conjugated teeth profiles, capable of ensuring an optimal tribological behavior of the contact.

Carrying out a bibliographic analysis on the topic [8 - 12] it was found that, in the vast majority, innovative mechanisms are manufactured from polymeric materials (MPM) and, less often - from metallic materials (MM). When using classic transmissions with toothed wheels, especially - for „open” type mechanisms - some undesirable problems appear, such as [11,12]: high noise, heating, vibrations, advanced corrosion, mass of mechanisms, high price of their manufacture, etc. For this reason, transmissions with metallic toothed wheels (RDM) are also subject to intensive wear, which lead to the appearance of metallic residues and anticipated damage, implying high costs for repair [10,12].

Some of these problems can be omitted at the design stage. Regrettably, many times even the designers with long experience in the field forget the golden rule: to choose the materials for manufacturing, in accordance with the formulated purpose.

Practically all transmissions required with heavy loads are made of metals. While the slightly requested ones - can be manufactured from both metals and plastic materials [8-12].

In general, the selection of materials for manufacturing gears is a great engineering challenge. The teeth of the gear wheels are subjected to quite difficult and severe loading conditions. There is simultaneous action of alternating normal and tangential dynamic stresses, contact deformations, accompanied by sliding friction. Gears are subjected to a series of requirements regarding strength, geometric accuracy, dimensional stability and increased durability. For the manufacture of toothed wheels, especially from thermoplastic materials, it was necessary to carry out a theoretical argumentation of selection, based on an extensive study of the existing late empirical research and to choose the most efficient couplings for TP, from the point of view of: the heat transfer from the contact area, the maximum possible lifespan in the lubrication medium, or in its absence.

Resulting from ensuring the optimal tribological behavior, through the theoretical research previously carried out by the authors [6,7], the *methodological premises for the possible selection of material couplings* in combinations were argued: „steel/steel”, „plastic/plastic” and „steel/plastic”.

2. MATERIALS AND RESEARCH METHODS

As a result of the previously conducted theoretical study [6, 7], an algorithm was developed for the possible selection of metal and plastic materials for the „satellite (Z_2) - immobile central wheel (Z_1)” and „satellite (Z_3) - mobile central wheel (Z_4) couplings”. According to this algorithm, the selection of combinations of metal and plastic materials in different versions of the couplings (steel-steel; steel-plastic; plastic-plastic) was argued, considering the ensurance of the tribological compatibility [8-12]:

The following brands of materials were purchased for research:

1. steel 40 Cr (GOST4543-71) with a hardness of 40-45 HRC (Chişinău, CESN GRUP SRL, str. Alba Iulia, 75);
2. plastics: PA6, POM, PEEK (Exporter: SC. CEPROINV S.A., str. Lucafărului no. 16, Cart. Mandrestt – cdd620043, Focşani-Romania WATT number RO1440484);
3. plastics reinforced with carbon fibers: PE66+GF30, PEEK+GF30.
4. grease MULTIS EP 2. <https://supraten.md/unsoare-total-multis-ep2-0-4kg-96374-ro>

Taking into account the specific aspect of the geometry and kinematics of the precessional gear, we resorted to modeling the „convex-concave” shape contact of the TP in „convex-convex” shape contact (cylindrical roller/cylindrical roller), fig.3, with the aim of adapting the model to the SMT-1 type installation, for experimental research (fig. 4,5), from the endowment of the „Tribology” laboratory of the TUM.

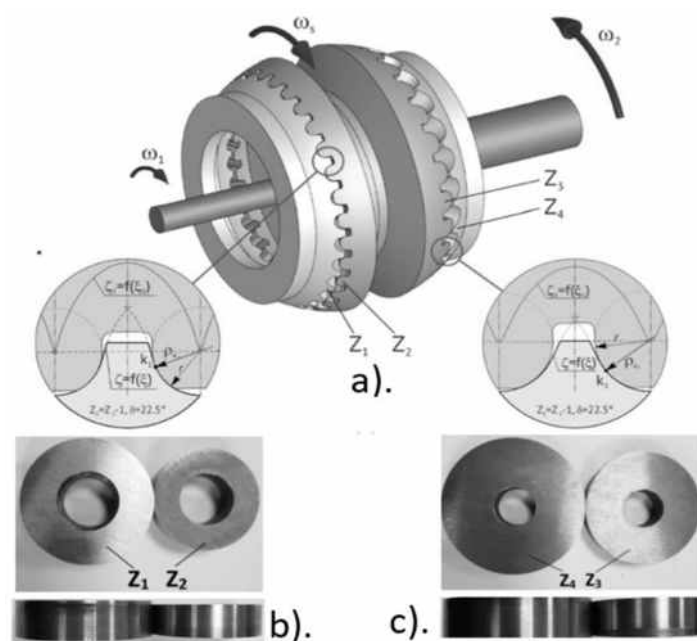

Fig. 3. General view representation of precessional transmission $A_{CX-CV}^{D(\beta)}$; and tooth flank profile shape (a); tribomodel of Z_1/Z_2 contact (b); tribomodel of Z_3/Z_4 contact (c)

The SMT 1 installation was modernized and adapted for computerized acquisition of *experimental data*, using certified transducers (fig. 4, 5) and signal acquisition and conditioning devices, produced by NATIONAL INSTRUMENTS. To process the experimental data, a software product was developed in the LabVIEW programming environment. The front panel of the data acquisition and processing program is shown in fig. 6.

Precessional gear contact modeling for tribological research

The geometric characteristics of the model (fig. 7b) in accordance with the geometric characteristics of the real (fig. 7a) precessional gear profile $A_{CX-CV}^{(D,\beta)}$ for the contact position points k_i when moving on the tooth flank.

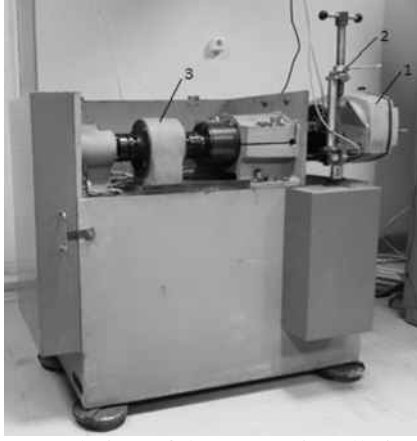

Fig. 4. General view of the SMT 1 installation (model 2070): 1 – Z_2 roller actuator; 2 – the contact loading device of the tribomodel with the normal force F_n ; 3 – the frictional torque transducer M_f



Fig. 5. Tribomodel of the precessional gear: Z_1 - model roller of immobile central wheel teeth; Z_2 - model roller of satellite wheel teeth; S - digital infrared pyrometric sensor for temperature measurement (model Impac IN 150)

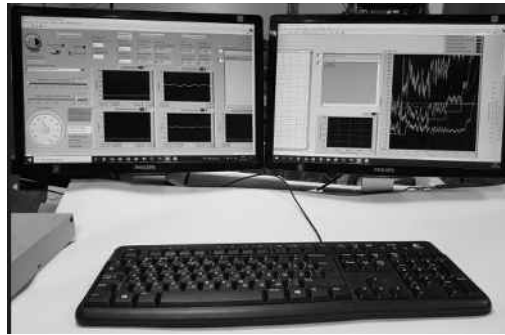

Fig. 6. Front panel of the Experimental Data Acquisition and Processing Software.

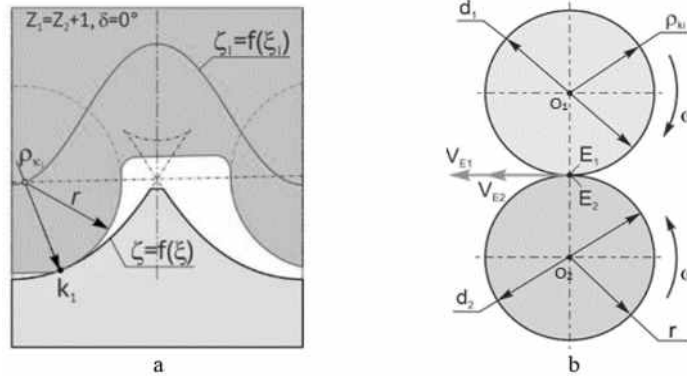

Fig. 7. The shape of the „convex-concave” contact made in the precessional gear $A_{(CX-CV)}^D$ (a) and of the model represented by cylindrical rollers (b)

When modeling the contact, the condition of geometric similarity between the gear and the tribomodel is imposed.

$$\begin{cases} \rho_{ki} - r = \Delta; \\ \frac{1}{r} - \frac{1}{\rho_{ki}} = K; \end{cases} \equiv \begin{cases} r_{1;4} - r_{2;3} = D; \\ \frac{1}{r_{2;3}} - \frac{1}{r_{1;4}} = K_e; \end{cases} \quad (1)$$

where: r_1 - radius of curvature of the roller equivalent to the tooth of the immobile central wheel Z_1 conjugated with the tooth of the satellite Z_2 ;

r_2 - radius of curvature of the roller equivalent to the tooth of the satellite Z_2 conjugated with the tooth of the immobile central wheel Z_1 ;

r_3 - radius of curvature of the roller equivalent to the tooth of the satellite Z_3 conjugated with the tooth of the mobile central wheel Z_4 ;

r_4 - radius of curvature of the roller equivalent to the tooth of the mobile central wheel Z_4 conjugated with the tooth of the satellite Z_3 ;

D - the difference in the radii of the model rollers;

K_e - reduced curvature of the roller surfaces of the model in the contact area.

Kinematically, contact modeling is done based on the peripheral velocities (V_{E1}, V_{E4} – of the surfaces of the central wheel teeth; V_{E2}, V_{E3} – of the surfaces of the satellite teeth) in relation to the instantaneous centers of rotation and the relative sliding velocities V_{al} of the surfaces in contact. The model requires the observance of equal values between the corresponding velocities in the gear and the model: $V_1 = V_{E1}$; $V_2 = V_{E2}$; $V_3 = V_{E3}$; $V_4 = V_{E4}$; $V_{alm} = V_{al}$, where: V_1, V_2, V_3, V_4 – the peripheral velocities of the model rollers; V_{alm} – the relative sliding velocity in the contact area of the model.

In the precessional transmissions of the $A_{CX-CV}^{D(\beta)}$ type the constructive and kinematic parameters of the tooth profiles (both their values and variations) in the contact area, depend on the constructive configuration ($\delta, \theta, \beta, Z_g, Z_g - Z_b \pm 1$) of the gear in each particular case (fig. 2). Due to these geometrical (variable radii of curvature ρ_{ki} - of the teeth of the central wheels in the area of the contact point ki when moving on the conjugated profiles of the precessional gear) and kinematical (variable peripheral velocities V_E and relative sliding velocities V_{al} of the surfaces of the tooth profiles in the contact area) peculiarities, tribological modeling is only possible for concrete positions of the contact point ki (corresponding to the angular position Ψ_{ki} of the crankshaft).

In the case of the tribological research of the materials used in the manufacture of the precessional gear wheels, the modeling was done for different ki positions of the contact point on the tooth profile. The modeling results for the points k_2 (fig.2) of the gears: Z_1Z_2 – immobile central wheel - satellite and Z_3Z_4 – satellite-mobile central wheel at the speed of the satellite shaft $n=3000$ [rpm], are presented in table 1.

Table 1. Geometrical and kinematic parameters of the equivalent tribomodel of gears Z_1Z_2 and Z_3Z_4 in the area of the contact point k_2 , at the speed of the satellite shaft $n=3000$ [rpm] ($\omega_1=314s^{-1}$), fig.3

The gear	Radius of curvature r_2 and r_3 [mm]	The radius of curvature of the tooth profile ρ_{21} and α , [mm]	Reduced curvature K , [1/mm]	The difference of the radii D (r_1-r_2) and (r_4-r_3) [mm]	The linear velocity V_{E2} and V_{E3} [m/s]	The linear velocity V_{E1} and V_{E4} [m/s]	The sliding velocity V of [m/s]	The diameter of the roller d_2, d_3 [mm]	The diameter of the roller d_1, d_4 [mm]
Z_1Z_2	2.233	2.998	0.1151	3.36	0.784	0.950	0.166	31.71	38.42
Z_3Z_4	2.442	3.002	0.0765	3.74	1.278	1.474	0.196	48.81	56.29

Similar calculations for the choice of the diameters of the tribomodel rollers (as needed) and for other ki points of the contact position on the tooth profile, arising from the conditions of the design specifications.

The tests are performed by loading the contact with the normal force (F_n) at peripheral and sliding velocities corresponding to the k_i point examined. The tribological behavior of the tested materials is established with the characteristics: 1. anti-friction properties – summary friction coefficient f_{Σ} ; 2. temperature T level in the contact area – generated from the friction process; 3. level (power) of energy dissipation in the contact area P_{dis} .

The model-samples, in the form of cylindrical rollers, were manufactured from the selected materials according to the dimensions established from the modeling conditions (tab.1) to ensure geometric and kinematic equivalence.

The specimens from the materials subjected to testing are executed according to the drawings, with the parameters corresponding to the calculated data. The constructive version of a specimen is presented in fig. 8.

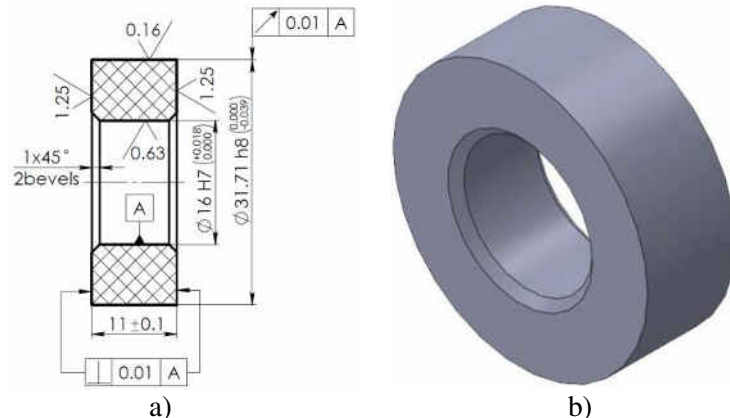

Fig. 8. Variant of the execution drawing of the specimen (a), and the three-dimensional aspect (b)

The contact surfaces of the rollers were machined by turning with the final grinding operation at the mechanical processing regimes, according to the recommendations [13]. The roughness parameters (tab.2) of the contact surfaces, resulting from the technological processing process and after the testing process, were recorded with the Taylor/Hobson type Surtronic 25 roughness meter (United Kingdom) [14].

Table 2. Roughnesses of friction surfaces

Roughness parameters of friction surfaces Ra; Rz (µm)										
Material coupling tested under conditions	The element model	The Z ₁ -Z ₂ coupling model				The element model	The Z ₃ -Z ₄ coupling model			
		Resulted from the technological process		Resulted from the testing process			Resulted from the technological process		Resulted from the testing process	
		Ra	Rz	Ra	Rz		Ra	Rz	Ra	Rz
Contact lubrication – without lubrication										
Steel 40Cr/ Steel 40Cr	Z ₁	0.3829	1.9231	0.6007	2.9877	Z ₃	0.9660	4.9850	0.6417	3.1959
	Z ₂	0.4155	2.1346	0.5009	2.3022	Z ₄	0.9831	4.9023	0.6256	2.9796
POM/POM	Z ₁	0.4861	2.5089	0.5536	2.8308	Z ₃	0.4175	2.1816	0.3087	1.4518
	Z ₂	0.4641	2.6354	0.4580	2.5061	Z ₄	0.4580	2.3207	0.5860	2.8896
Steel 40Cr/ POM	Z ₁	0.4168	2.0801	0.2684	1.4130	Z ₃	0.4262	2.1087	0.4348	2.0105
	Z ₂	0.4382	2.3036	0.3961	1.9560	Z ₄	0.4580	2.3207	0.2756	1.4247
Contact lubrication – grease MULTIS EP 2 (TOTAL)										
Steel 40Cr/ Steel 40Cr	Z ₁	0.3760	1.8423	0.3208	1.8162	Z ₃	0.4372	2.3611	0.4043	2.1568
	Z ₂	0.3388	1.6846	0.3199	1.6719	Z ₄	0.4364	2.3165	0.3945	1.8761
POM/POM	Z ₁	0.4808	2.4899	0.3420	1.6831	Z ₃	0.3894	1.9954	0.3439	1.8039
	Z ₂	0.4501	2.3245	0.4039	2.0746	Z ₄	0.3508	1.7217	0.3896	2.1102
Steel 40Cr/ POM	Z ₁	0.4994	5.326	0.4671	2.2849	Z ₃	0.4145	2.0607	0.4126	2.1476
	Z ₂	0.4362	2.3035	0.1956	1.1056	Z ₄	0.7919	3.5717	0.4790	2.3900

In the testing process, the installation endowed with the computerized system for the acquisition of experimental data and the Specialized Software, developed in the LabView Programming environment, allows the automatic recording and storage of the signals of the normal load force of the contact (F_n), the frictional torque (M_{fr}), the temperature in the contact area (T) and of the summary friction coefficient (f_{Σ}).

An example of the acquired data is shown in fig. 9.

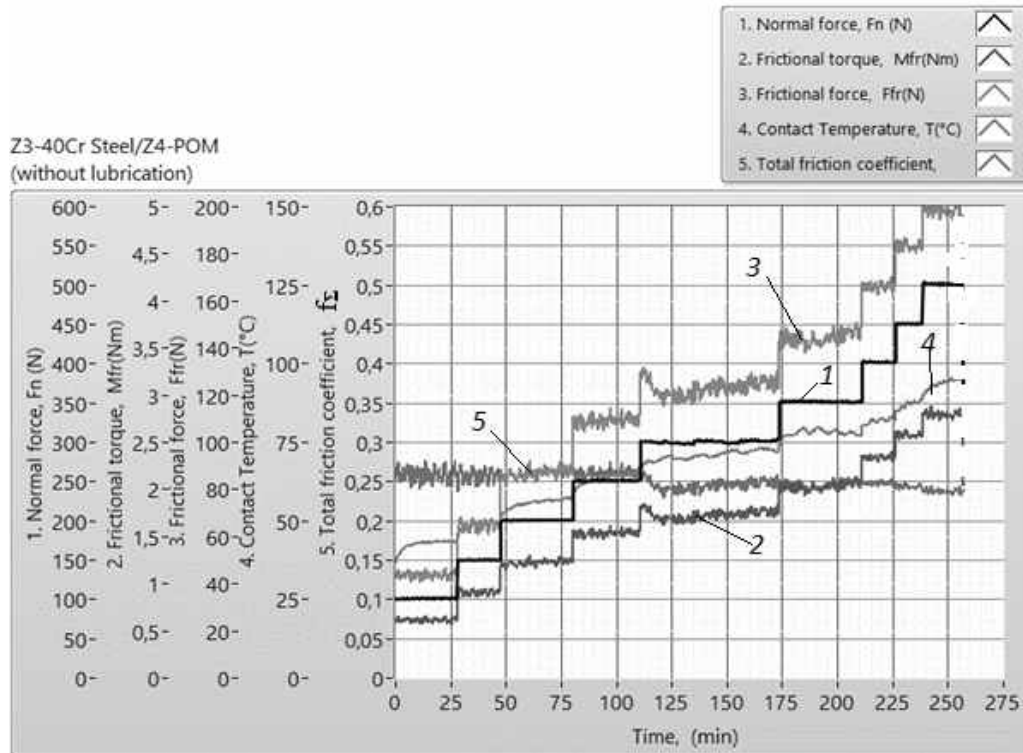

Fig. 9. Evolution over time of the tribological parameters (F_n , M_{fr} , F_{fr} , T , f_{Σ}) during the step loading of the contact with the normal force, ($\Delta F_n = 50N$)

The experimental data of the measured tribological characteristics were subjected to statistical processing with the assessment of mean values and standard deviations. As an example of statistical processing, there are presented the mean values of the summary friction coefficient f_{Σ} (with the limits of standard deviations) when loading the contact with the normal force F_n (fig. 10) and tab. 3.

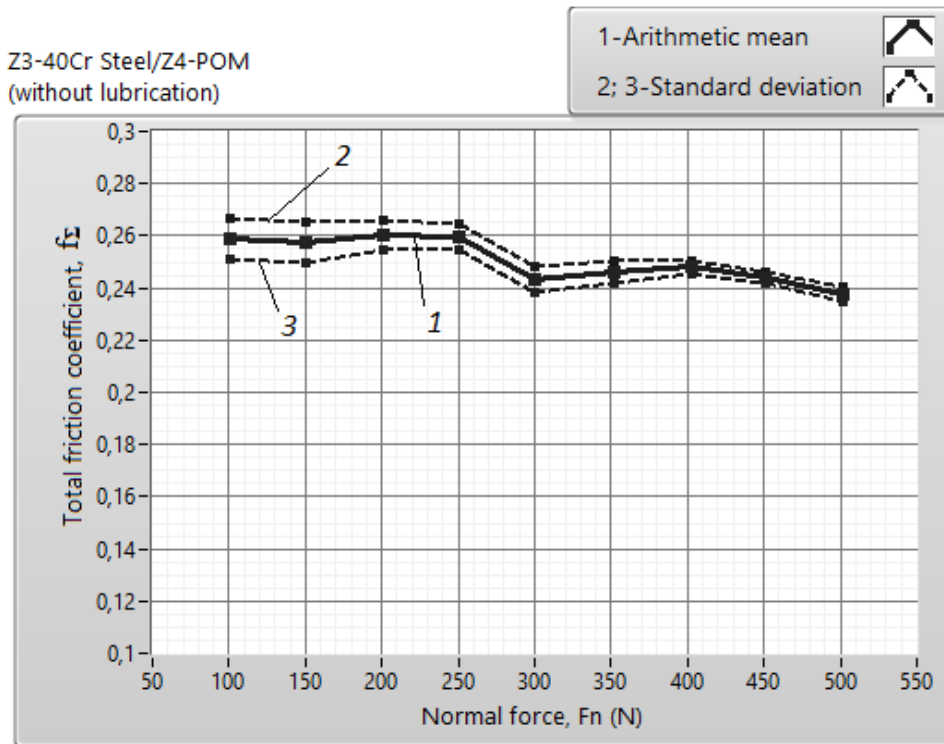

Fig. 10. The summary friction coefficient (f_{Σ}):
1 – mean value; 2, 3 – standard deviation

Table 3. Example of the data presented in fig. 9, processed statistically
Z3-40Cr Steel/Z4-POM (without lubrication)

F_n (N)	Mfr, (Nm)	Dev.St. Mfr	Ffr, (N)	Dev.St. Ff	T (°C)	Dev.St. T	C. fr.	Dev.St. C
101,296	0,738	0,022	26,213	0,798	57,164	1,116	0,259	0,008
150,407	1,090	0,032	38,736	1,150	64,846	1,277	0,258	0,008
200,868	1,471	0,032	52,273	1,133	74,228	1,720	0,260	0,006
250,945	1,833	0,036	65,139	1,287	82,825	1,037	0,260	0,005
300,342	2,058	0,047	73,113	1,656	94,387	1,205	0,243	0,005
351,884	2,437	0,043	86,591	1,543	104,048	1,282	0,246	0,005
402,137	2,807	0,027	99,750	0,955	108,947	1,141	0,248	0,002
450,987	3,096	0,029	110,003	1,018	116,071	1,448	0,244	0,002
501,520	3,356	0,039	119,248	1,384	124,804	2,094	0,238	0,003

3. THE RESULTS OF SCIENTIFIC RESEARCH AND DISCUSSIONS

In the framework of this paper, the following pairs of materials were subjected to experimental tests: Steel 40Cr/Steel 40Cr, POM/POM, Steel 40Cr/POM.

Chemical composition and characteristics of materials:

3.1. Steel 40Cr [13] (Fe,%-97; C-0.36...0.44; Si,%-0.17...0.37; Ni,% - up to 0.3; Mn,% - 0, 5...0.6; Cr,% - 0.8...1.1; Quenching in oil (T=860°C) and tempering (500-800°C).

Strength Limit: RB-665 MPa; Yield strength, σ_{02} - 490 MPa; HB hardness – 212...248;

Plastic characteristics: relative elongation, δ - 15%; plasticity at shock, 59 J/cm²).

3.2. POM [14] (POM plastic mass – polyamide, or polyacetal-structural formula [CH₂O]_n; density- 1.41 g/cm³; melting point- 175°C; breaking limit: 70-80 MPa; coefficient of friction at sliding (coupled with Steel): f=0.25-0.45; recommended operating temperature range [15, 16]: dimensionally stable precision parts, small modulus toothed wheels, machine parts in permanent contact with water, rollers, cams, etc.

According to the purpose, the tribological behavior of the mentioned couplings of materials according to the geometric, kinematic and loading conditions of the precessional transmissions was studied.

For the comparison of the results, Steel 40Cr/Steel 40Cr were accepted as „standard coupling” in operating conditions without and with lubrication. In the experiment, the contact loading was carried out in steps, with its maintenance over time until the stabilization of the temperature (T) in the friction area. The load level is limited to the appearance of a behavior with qualitative changes in the evolution of tribological parameters and working surfaces. Thus, for the „standard coupling”, in the absence of lubricant, at the load of the contact of approx. 400N and at the temperatures of 80-120°C, there were symptoms of changes in the contact surfaces with a change in their color to reddish-brown layers of friction surfaces. This effect, according to research confirmations [16, 17], is probably related to the „fretting-corrosion” effect, which is mainly achieved for couplings made of metallic materials. This effect was observed in both models of the gears (Z_1/Z_2 and Z_3/Z_4) fig.11.

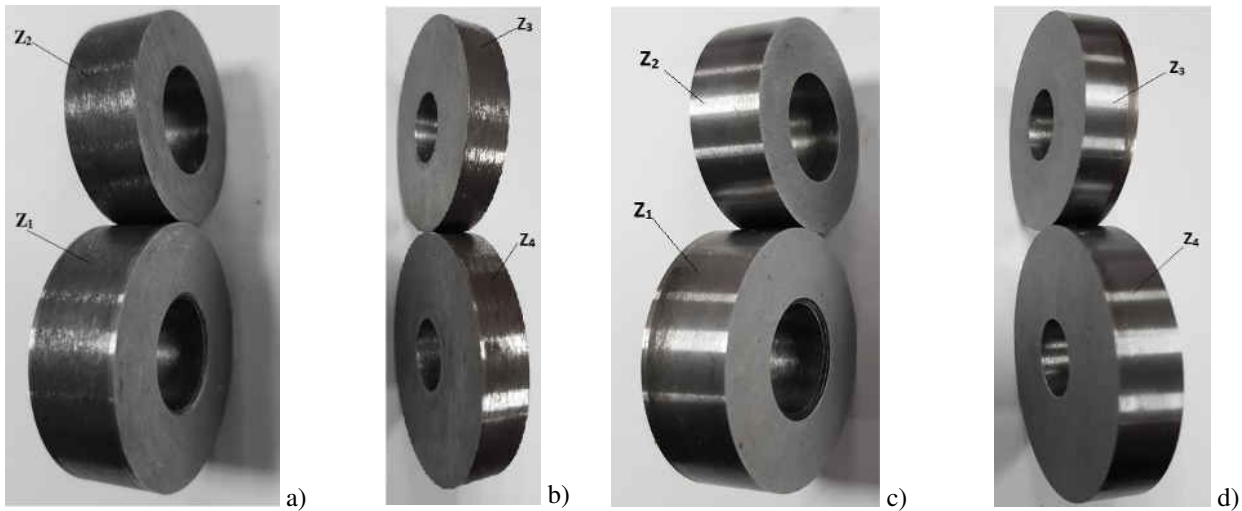

Fig. 11. The contact surfaces of the tribomodel rollers of the precessional gear subjected to the fretting-corrosion effect: a- the tribomodel Z_1/Z_2 ; b – tribomodel Z_3/Z_4 . Material steel 40Cr/steel 40Cr. Lubrication - without lubrication.

The contact surfaces of the tribomodel rollers resulting from the test process with contact lubrication: c- the tribomodel Z_1/Z_2 ; d – tribomodel Z_3/Z_4 . Lubrication - grease MULTIS EP 2. Material: steel 40Cr/steel 40Cr.

The changes observed on the contact surfaces are also confirmed by the microgeometric change R_a and R_z (tab.2). In the case of the coupling Z_1/Z_2 : for the surface Z_1 – the initial roughness: $R_a=0.3829 \mu\text{m}$ and $R_z=1.9231 \mu\text{m}$, the final roughness Z_1 : $R_a=0.6007$, $R_z=2.9877$; for Z_2 – the initial roughness: $R_a=0.4155 \mu\text{m}$ and $R_z=2.1346 \mu\text{m}$, the final roughness: $R_a=0.5009 \mu\text{m}$ și $R_z=2.3022 \mu\text{m}$.

In the test process, without lubrication for the given coupling (Z_1/Z_2) the summary friction coefficient (f_Σ) when the contact is loaded with the normal force (F_N) up to the limit value of 500 N, varies in the range of 0.485-0.508, and the temperature (T) in the contact area during testing increases from the initial value $T=52^\circ\text{C}$ to the final value $T=127^\circ\text{C}$. A similar trend of tribological behavior is also observed for the coupling Z_3/Z_4 ($f_\Sigma = 0.48-0.58$; $T= 39-104^\circ\text{C}$).

In the test process with lubrication (grease MULTIS EP2 [17]) – the tribological behavior of the contact changes essentially: for the coupling Z_1/Z_2 the friction coefficient (f_Σ) decreases by about 6 times and varies within the limits of 0.056-0.087, and the temperature during the testing period it varies from 36 to 51°C, for the values of the normal load force (F_N) within the limits of 100..500N. Initial surface roughness: for element Z_1 – the initial roughness: $R_a=0.3760 \mu\text{m}$ and $R_z=1.8423 \mu\text{m}$, the final roughness: $R_a=0.3208 \mu\text{m}$ and $R_z=1.8162 \mu\text{m}$; for element Z_2 – the initial roughness $R_a=0.3388 \mu\text{m}$ and $R_z=1.6846 \mu\text{m}$, the final roughness: $R_a= 0.3199 \mu\text{m}$ and $R_z= 1.6719 \mu\text{m}$.

The appearance of the contact surfaces, resulting from the testing process, are shown in fig. 12.

The results of the tests of the couplings of materials taken into study are presented in fig. (13, 14) and table 2.

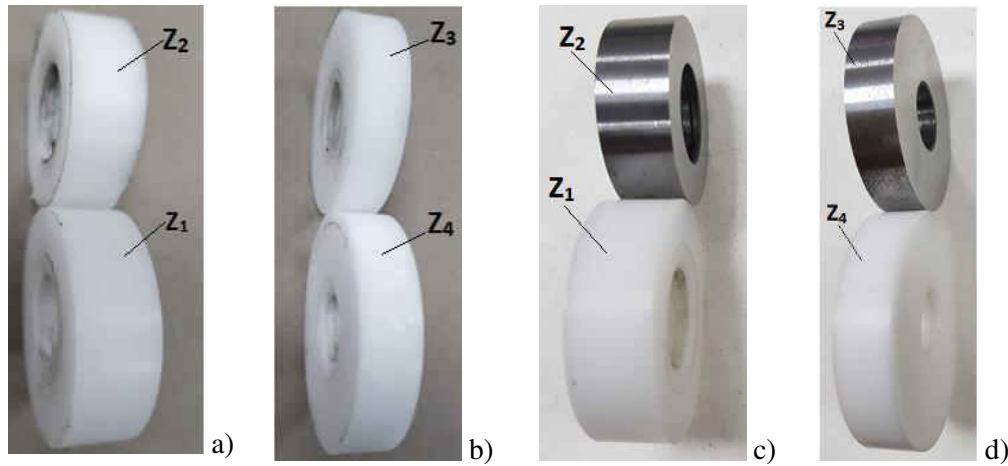

Fig. 12. Contact surfaces of the tribomodel rollers resulting from the test process with contact lubrication: a - tribomodel Z_1/Z_2 (material POM/POM); b – tribomodel Z_3/Z_4 (material POM/POM); c- tribomodel Z_1/Z_2 (material POM/ steel 40Cr); d – tribomodel Z_3/Z_4 (steel 40Cr / material POM), lubrication – grease MULTIS EP 2

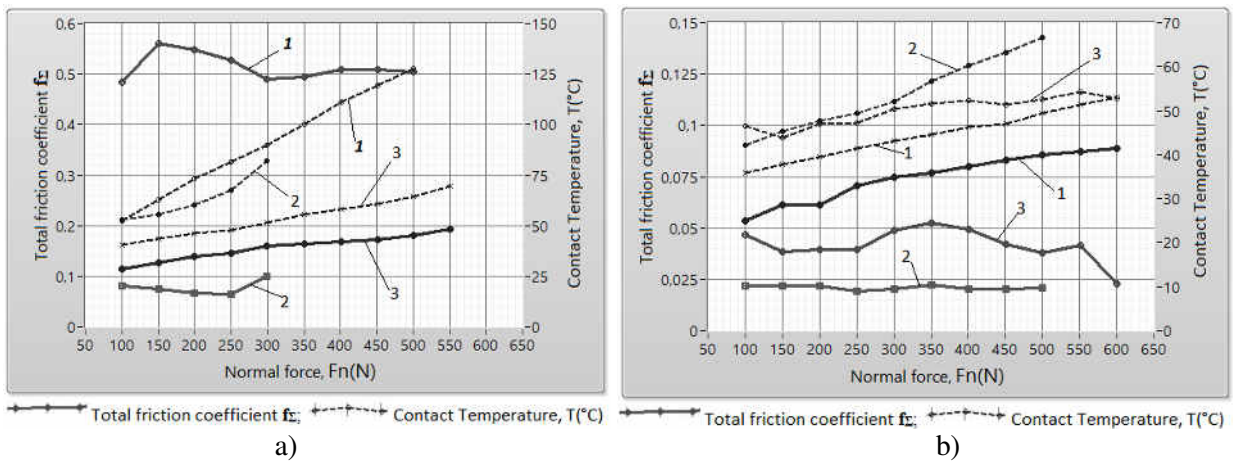

Fig. 13. Model of the coupling Z_1/Z_2 . The variation of the friction coefficient (f_Σ) and the temperature in contact (T) for the couplings of materials: 1 - (Z_1 -40Cr Steel/ Z_2 -40Cr Steel); 2 - (Z_1 -POM/ Z_2 -POM); 3 -(Z_1 -40Cr Steel/ Z_2 -POM). Lubrication: a – without lubrication; b – lubrication with grease MULTIS EP 2

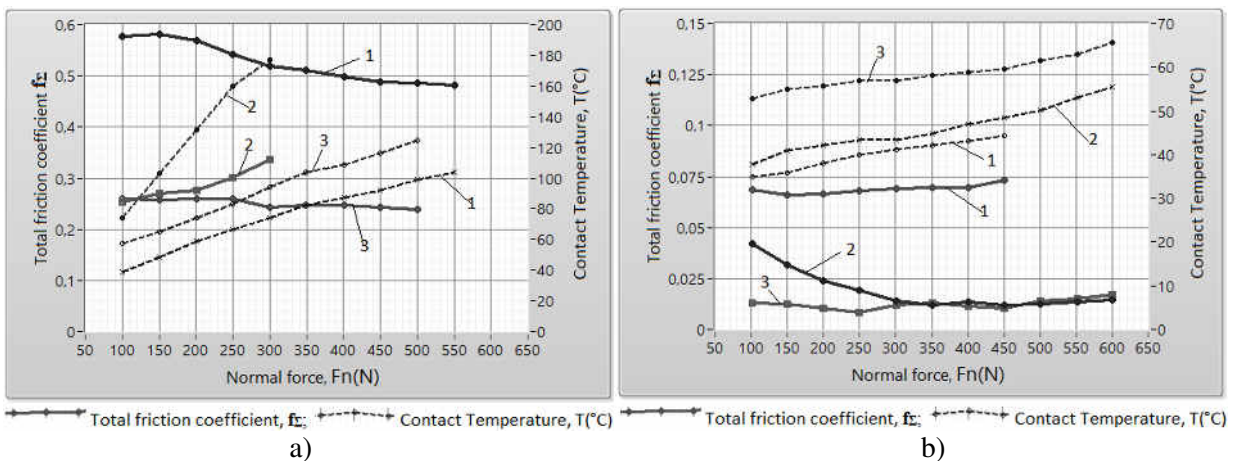

Fig. 14. Model of the coupling Z_3/Z_4 . The variation of the friction coefficient (f_Σ) and the temperature in contact (T) for the couplings of materials: 1 - (Z_3 -40Cr Steel/ Z_4 -40Cr Steel); 2 - (Z_3 -POM/ Z_4 -POM); 3 -(Z_3 -40Cr Steel/ Z_4 -POM). Lubrication: a – without lubrication; b – lubrication with grease MULTIS EP 2

As a result of the research carried out on tribomodels, a different behavior of the materials was established both according to the level and mode of variation of the friction coefficient, as well as of the temperature generated in the friction process in the contact area. Thus, for the coupling of POM/POM materials (fig. 13), tested for the Z_1/Z_2 model, in the absence of the lubricant, the friction coefficient (f_Σ) varies within the limits of 0.08...0.1 with a decrease in the value of about 5 - 5.5 times compared to the benchmark coupling. The tendency and intensity of

the temperature increase (T) in the contact area is relatively high compared to the level of the friction coefficient (0.08 – 0.1) at a power dissipation of energy (P_{dis}) of about (3...5) W. This is due to the reduced capacity of heat transfer from the contact area of the triboelements, made of POM thermoplastic material. Testing under these conditions for the POM/POM coupling, revealed a reduced load capacity for a normal contact operation of up to 200...250 N, with a temperature level between 50-70°C.

In the case of the Z_3/Z_4 model without lubrication (fig. 14,a) the same indicators (f_{Σ} and T) have a different character, in particular – according to the level. The friction coefficient in this case takes on values within the limits of 0.25...0.35, and the temperature (T) in the contact area changes within the limits of (65...180)°C, at the loading load F_N up to 300N. The maximum temperature level in the contact area approaches the melting point of the material (POM - 175°C). Due to this fact, defects in the form of exfoliation of the superficial layer were detected on the friction surface.

The use of POM/POM materials for the Z_3/Z_4 gear elements of the precessional transmission can be problematic due to the high level of energy dissipated by friction due to the generation of high temperatures in the contact area.

An essential improvement in the tribological condition of the contact is produced in the case of the use of lubricating materials. In particular, for contact lubrication with the grease MULTIS EP 2, in both models (Z_1/Z_2 and Z_3/Z_4) an essential reduction of the friction coefficient (f_{Σ}) (by 4...5 times) occurred, up to the level of 0.01 0.03 (fig. 13, 14). At the same time, the temperature level in the contact area has also decreased within the limits of (40-70)°C. This led to the broadening of the load range of the contact normal force F_N up to (500-600)N. Based on the above, it can be recommended for the execution of the elements of the precessional gear (toothed wheels) of the POM material under conditions of lubrication with MULTIS-EP 2 grease.

In the case of the tribomodel study (Steel40Cr/POM) the same test parameters were studied. As a result of the research carried out, the same rules of behavior of the tribomodels were detected in the absence and presence of the lubrication medium. Testing of these materials in the Steel40Cr/POM coupling, for both types of gear models (Z_1/Z_2 and Z_3/Z_4), in operating conditions without lubrication and with lubrication, demonstrated an effective tribological behavior according to the level of the friction coefficient (f_{Σ}) and of the temperature in the contact area in a wide range of loading with the normal force (F_N) of the contact up to 500...600N. In the absence of lubricant, the friction coefficient (f_{Σ}) for the Z_1/Z_2 model, varies within the limits of 0.12...0.2 (fig. 13 a), and for the Z_3/Z_4 model - takes values of approximately 0.25 (fig. 14 a). The temperature in the contact area, due to more efficient heat transfer through the metal element, is reduced from 180°C to \approx 120°C. This behavior makes it possible to use the coupling given by the materials for the manufacture of precessional gear elements under lubrication-free operating conditions. When using the MULTIS-EP 2 lubricant, the operating conditions of the contact improve. The friction coefficient (f_{Σ}) for the Z_1/Z_2 model takes values from 0.025 to 0.05 (fig. 13b), and for the Z_3/Z_4 model there was an essential decrease up to 0.01 (fig. 14b). This behavior demonstrates an influence on the tribological state, shape, dimensions and kinematics of the surfaces in the contact area. Due to reduced energy losses and improved heat transfer, the temperature in the contact area is maintained at (60-65)°C throughout the load range ($F_N=100...600$ N). Compared to the reference model, the Steel40Cr/POM (Z_3/Z_4) tribomodel in the presence of the lubricant, the friction coefficient decreases by approximately 40...45 times (fig. 14a curve 1 and 14b, curve 3) 1a, 3b).

4. CONCLUSIONS

In the result of the research carried out and presented in figures 13, 14 and table 2 it is found:

4.1. The coupling of materials Steel40Cr/Steel40Cr can be used in the construction of the precessional gear only in operating conditions with contact lubrication. In particular when lubricating the contact with MULTIS EP 2 grease, the load range widened to the normal force $F_N=500$ N.

4.2. Couplings of polymer materials of the POM type can be used without lubrication, only at relatively low loading loads, for the normal force F_N not higher than 200N. When lubricating the contact with MULTIS-EP 2 grease, the energy losses in the contact area decrease essentially, the friction coefficient f_{Σ} stabilizes at the level of 0.01...0.12, at a wide range of the load force F_N up to 600N.

4.3. The coupling of materials Steel40Cr/POM can be used in non-lubricated and lubricated operating conditions. When used with lubrication, the friction coefficient decreases to 0.01...0.05, compared to the value of the friction coefficient in operating conditions without lubrication - 0.15...0.25. This leads to a high energy efficiency of the precessional gear contacts under lubricated operating conditions (MULTIS-EP 2 grease).

4.4. Based on the analysis of the research carried out, when choosing the materials for the design of precessional transmission gears operating in lubrication conditions, priority is given to the Steel40Cr/POM coupling.

Acknowledgements: The article was published by the authors by conducting scientific research under the State Research-Innovation Project, No. 160-PS of 31.01.2020 "Increasing the competitiveness of precessional transmissions by developing and capitalizing on the gear with conform contact of the teeth and expanding their application area". Project number 20.80009.700.24, dated 31.01.2020. Project leader - Acad. Ion Bostan.

REFERENCES

1. Bostan, I., (2019). *Transmisii Precesionale (Precessional transmissions)*, Vol. 1 (synthesis, Kinematics and Calculation elements), „Bons Offices” Publishing House, Chisinau, 477.
2. Bostan, I., (2022). *Transmisii Precesionale (Precessional transmissions)*, Vol. 2, „Bons Offices” Publishing House, Chişinău, 667.
3. Bostan, I., (1986). *Transmisie precesională dinţată (Geared precessional transmission)*, BI SU 1455094 AI, SSSR.
4. Bostan, I., (1991). *Preţessionâe peredaci s mnogoparnâm zaţepnienem*. Izd. „Ştiinţa”, Chişinău, 341 s.
5. Bostan, I., (2022). *Transmisii Precesionale (Precessional transmissions - Surface generation and Applications)*, Vol. 3, „Bons Offices” Publishing House, Chişinău, 589.
6. Bostan, I., Stoicev, P., Buga, A., Poştaru, G., Trifan, N., Platon, A., (2022). *Theoretical contributions on the selection of possible tribological couples of materials for the manufacture of precessional transmissions*, Journal of Engineering Science, XXIX(1), 23 – 47.
7. Bostan, I., Stoicev, P., Poştaru, G., Vaculenco, M., Buga, A., Culev, M., Poştaru, A., Platon, A., (2022). *Theoretical and experimental modelling of the tribological behaviour aspects of contact elements in the precessional gearing (PG)*, Journal of Engineering Science, XXIX(2), 8 – 17.
8. Ripa, M., Deleanu, L., (2008). *Deteriorări în tribosisteme (Damage in tribosystems)*, Zigotto Publishing House, Galaţi, 271.
9. Carapetyan, A.N., Şarr, G., (2007). *Vîbor polimernîh materialov pri konstruirovaniî zubciatîh colios*. Materialovedenie. Izv. NAN RA i GIUA. Ser. TN. 2007.T.LX, № 2, s. 266-271.
10. Carapetean, A.N., Rymuza, Z., Cuşnierevici, Z., (2004). *Tribologhiceschie svoistva polimer-polimernîh par*, Trenie i iznos, T.25, 3; s. 292-305.
11. *Zubciatîi peredaci iz polimernîh materialov*. <https://themechanic.ru/polymer-gears>, accessed 07/02/2023.
12. Michel Biron, (2018). *Termoplastice şi Materiale Compozite*, 3-a, pp. 1164.
13. E`nciklopedia po Mashinostroeniyyu XXL (oborudovanie, mehanika, materialovedenie...), s.168-173, <https://mash-XXL.info>info>
14. Ruzozimetrul Taylor/ Hobson, available at <http://www.taylor-hobson.com>, accessed 06/02/2023.
15. Stal` 40x- GOST4543-2016. <http://www.atissteel.ru/stal-40h-harakteristiki>, accessed 10/02/2023.
16. Mase plastice POM, available at: <http://www.isar.com.ro>, accessed 25/01/2023.
17. Polyushkin N.G., (2013). *Osnovy` teorii treniya, iznosa I smazki: ucheb. Posobie*, Krasnoyar. Gos. Agrar. Un-t. – Krasoyarsk, 192 s.
18. Ştefănescu I., Deleanu L., Ripa M. (2008). *Lubrifiere şi lubrifianţi*. Ed. EUROPLUS, Galaţi, pp. 360.
19. https://www.total-er.com/sites/g/files/wompnd1106/f/atoms/files/multis_ep_2.pdf, accessed 31/01/2023.