

The Impact of Three-Phase Smart Gate Drivers on the Performance and Safety of PMSM and BLDC Motor Drives

Pascari Sergiu, Bîrnaz Adrian, Rusu Nicolae

Technical University of Moldova, Department of Microelectronics and Biomedical Engineering, Center of Nanotechnology and Nanosensors, sergiu.pascari@mib.utm.md, adrian.birnaz@mib.utm.md, 0000-0002-2906-7255, 0000-0001-7006-3443, 0009-0008-4401-3686, mib.utm.md

Keywords: smart gate driver, slew rate control, integrated protection, motor control

Abstract. Three-phase smart gate drivers (SGDs) have revolutionized the control of high-performance permanent magnet synchronous motors (PMSMs) and brushless direct current (BLDC) motors. [1] Smart Gate Drive offers an intelligent solution for driving and protecting the exterior Power MOSFETs. This feature allows system designers to adjust MOSFET slew rate, optimize switching and electromagnetic interference (EMI) performance, reduce bill of materials (BOM) numbers, automatically generate dead times, and provide additional protection for external power MOSFETs and the drive system. This makes them highly effective for use in demanding environments where motor performance and safety are critical and are widely used in industrial automation, automotive systems, drones and robotics.

Introduction. This article examines the impact of the three-phase smart gate driver on motor performance and safety. Key advantages over traditional gate drivers will be discussed, including reduced switching loss and increased fault tolerance. For comparison, Infineon's [2] MOTIX™ 6EDL7141 IC, which is a gate driver IC for three-phase BLDC or PMSM applications, and a [3] IR2104(S) which is a high-voltage MOSFET and IGBT, power great. driver with dependent high and low reference output channels. Figure 1 gives the difference between the wiring of an SGD unit and a regular gate driver or three-phase configuration, the former in turn can offer a wide range of settings and built-in protections, and the latter only gate control.

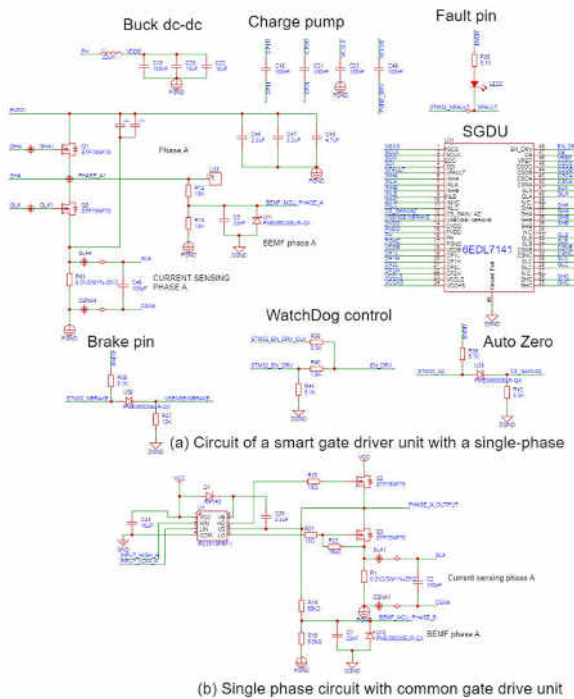

Fig.1. Circuit comparison of (a) a smart gate driver with additional safety wiring and (b) a conventional single-phase gate driver

The study was supported by the by State Program LIFETECH « Innovations in Biomedical Engineering: Advanced Technologies and Applications for Data Acquisition, Processing and Analysis » No. 020404 at Technical University of Moldova.

References

- [1] N. Oborny, "Understanding Smart Gate Drive," Jun. 2015. [Online]. Available: www.ti.com
- [2] "MOTIX™ 6EDL7141 Datasheet Product Feature Summary." [Online]. Available: www.infineon.com
- [3] "HALF-BRIDGE DRIVER Features." [Online]. Available: www.irf.com