

POLARIZATION SENSIBLE DEVICES BASED ON BIREFRINGENT CRYSTALS

N. N. Syrbu*, A. V. Dorogan, I. G. Stamov, V. V. Dorogan

Technical University of Moldova, Chisinau, Bd. Stefan cel Mare 168, Chisinau, MD-2004, Moldova

*E-mail: syrbunn@yahoo.com

An increase of the data carrying frequencies occurs in modern communication systems as the demand of data flow increases. Devices of direct and indirect interleaving operation are used for dividing two neighbored impulses into two different channels. The deinterleaving devices divide the common input pack of channels and guides through two output flows. The interleaving device does the inverse process [1-3].

The absorption edge for ZnAs₂ single crystals does not coincide at E||c and E⊥c polarizations and 20°C. It has a sharp increase at 1.35 μm for the E||c polarization and becomes transparent for the crystals with hundreds of microns thickness. The crystals are transparent till the 1.3 μm wavelength at E⊥c polarization. The deinterleaving and interleaving operations for detecting signals placed at nearby frequencies, which can be achieved using a simple device based named the Acusto-optic Tunable Filter – AOTF [3]. The usage of optic properties of the ZnAs₂ anisotropic crystals allow to solve an analogical problem and are better conformed to the planar technologies.

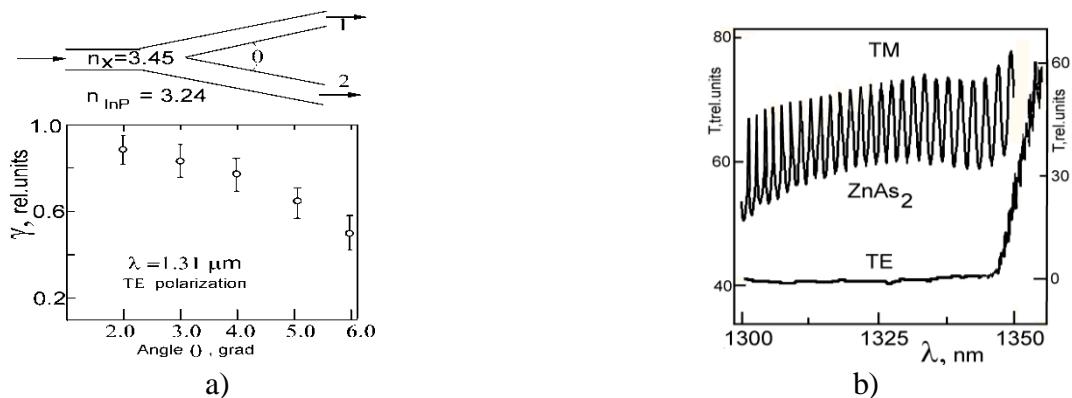

Figure 1. a) A schematically represented splitter on immersed waveguides on the basis of Al_xGa_{1-x}As(x=0.4)/GaAs heterostructures and the measurement of the dependence of its transmission coefficient on the ramification angle θ ; b) TE and TM mode selection of ZnAs₂ films.

Figure 1 shows the experimental dependence of the transmittance coefficient of the Y-splitter, being determined as the correlation of the sum power of two output branches and the power of the input branch, with a ramification angle θ . A polarization-selective connection of the two waveguides can be obtained by making the parameters k or $\Delta\beta$ with a strong polarization dependence. The difference Δn (0.08-0.1) between the refraction indices of the base and the waveguide was the same for both waveguides.

Figure 2, (a) shows the device construction, which uses an electro-optical waveguide structure, limited at both sides by films based on ZnAs₂ single crystals. Two impulses λ_1 and λ_2 are injected at the input of the device, consisted of two modes TE and TM. The input film is transparent for both wavelengths with TE polarization, as it is shown in the figure. If applying a voltage at K2 contacts, the TE mode of both wavelengths λ_1 and λ_2 , changes into TM, due to the electric field applied to the contact. The output ZnAs₂ film, with the crystallographic axis C oriented vertically, will be transparent for the impulses with TM mode in the α channel, i.e. the initial wavelengths λ_1^{TE} and λ_2^{TE} . All the wavelengths from the β channel will be blocked. In this case, the device is functioning in switching regime of TE modes of the polarized signals λ_1 and λ_2 . In order to realize the switching of

λ_1^{TM} and λ_2^{TM} wavelengths it is necessary to change the crystallographic axis C of the input and output films by 90 degrees.

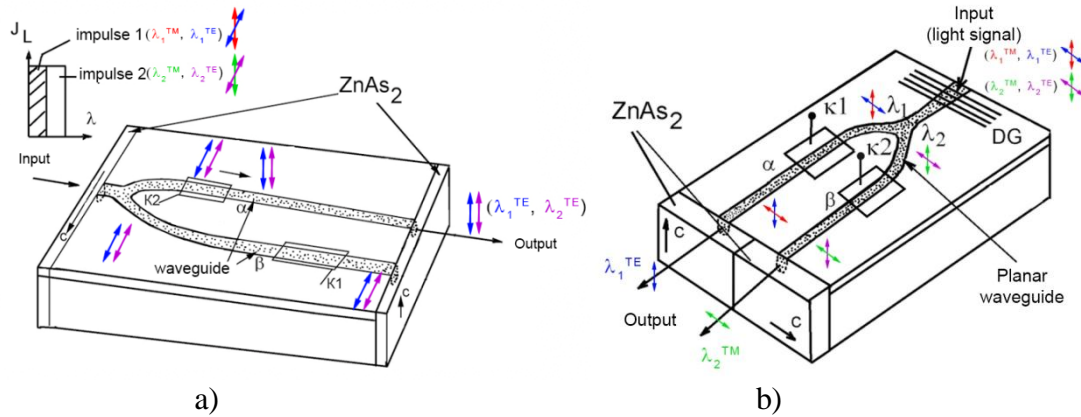

Figure 2. Device models using ZnAs₂ films for dividing communication channels with λ_1 and λ_2 wavelengths, for the case of polarized light.

Figure 2, *b* shows the construction of a selector (filter, separator) of modes consisted of electro-optical waveguides and ZnAs₂ films positioned at the output of α and β channels, with the crystallographic axes C respectively perpendicular. Two impulses λ_1 and λ_2 , which are consisted of TE and TM modes, are injected at the device input. The diffraction grating at the device input leads the λ_1 and λ_2 impulses with TM and TE modes into α and β waveguides. The polarization plane of both modes is changed by a 90 degrees value for both wavelengths by applying a voltage at the contacts K1 and K2. The output ZnAs₂ film of the α channel will be transparent for the TM mode, i.e. the initial wavelength λ_1^{TE} , and the one from β channel will be transparent for λ_2^{TM} . If there is no voltage applied to K1 and K2 contacts, the λ_1^{TM} wavelength will be received at the output of α channel, and λ_2^{TE} at the output of β channel. In this case the device works as a selector (filter, separator) of components of polarized radiation, which corresponds to the wavelengths of optical communication channels.

Conclusions. ZnAs₂ is effectively separating the modes of the optic impulses and in common with acusto-optic waveguides of different type permits manufacturing devices for deinterleaving operation of the optic impulses in fiber optic communication systems working in the region of 1.3 μ m.

- [1]. Bob Shine and Jerry Bautista, *Interleavers Make High-channel-count Systems Economical* (Wavesplitter Technologies), **Lightwave**, August 2000, page 140.
- [2] H. Mrtzner, J. Eberhardt, J. Cieslak, Th. Hahn, R.Goldhahn, U.Reislohner, W.Withuhn, *Thin Solid Films*, **451-452** (2004) 241-244.
- [3] Harry J. R. Dutton, *Understanding Optical Communications*. International Technical Support Organization, September, 1998.