

[https://doi.org/10.52326/jes.utm.2023.30\(1\).08](https://doi.org/10.52326/jes.utm.2023.30(1).08)  
UDC 621.384:615.831.7



## A MATERIAL FULL OF PROMISES: Hg<sub>1-x</sub>Cd<sub>x</sub>Te - MERCURY CADMIUM TELLURIDE

Titu-Marius I. Băjenescu\*, ORCID: 0000-0002-9371-6766

Swiss Technology Association, Electronics Group Switzerland

\*Corresponding author: Titu-Marius I. Băjenescu, [tmbajenesco@gmail.com](mailto:tmbajenesco@gmail.com)

Received: 01. 24. 2023

Accepted: 02. 03. 2023

**Abstract.** In recent decades' doctors and scientists have intensively researched the effect of infrared applications. The rays of infrared devices penetrate the body to a depth of about 5 cm and provide a pleasant warmth, stimulating blood circulation and reducing joint pain. Long-wave infrared light exerts a beneficial effect on nerve cells. These nerve cells are responsible for transmitting the sensation of pain to the brain. Infrared light treatment increases the release of endogenous analgesic substances from the brain and adrenal glands, such as enkephalins and endorphins. The infrared range of the electromagnetic spectrum extends from about 0.75  $\mu\text{m}$  to 1000  $\mu\text{m}$ . The article presents a review of HgCdTe infrared detectors, which have been intensively developed in the last forty years since the first synthesis of this compound semiconductor in 1958.

**Key words:** *infrared detectors, trichromats, ROIC, FPA, Sofradir, CEA-Leti, stimulating blood circulation, infrared applications.*

**Rezumat.** În ultimele decenii, medicii și oamenii de știință au cercetat intens efectul aplicațiilor în infraroșu. Razele infraroșii pătrund în corp până la o adâncime de aproximativ 5 cm și oferă o căldură plăcută, stimulând circulația sângelui și reducând durerile articulare. Lumina infraroșie cu undă lungă exercită un efect benefic asupra celulelor nervoase. Aceste celule nervoase sunt responsabile de transmiterea senzației de durere către creier. Tratatamentul cu lumina în infraroșu crește eliberarea de substanțe analgezice endogene din creier și glandele suprarenale, cum ar fi encefalinele și endorfinele. Intervalul infraroșu al spectrului electromagnetic se extinde de la aproximativ 0,75  $\mu\text{m}$  la 1000  $\mu\text{m}$ . Articolul prezintă o trecere în revistă a detectoarelor cu infraroșu HgCdTe, care au fost dezvoltate intens în ultimii patruzeci de ani de la prima sinteză a acestui semiconductor compus în 1958.

**Cuvinte cheie:** *detectoare în infraroșu, tricromate, ROIC, FPA, Sofradir, CEA-Leti, stimularea circulației sanguine, aplicații în infraroșu.*

### 1. Introduction

Light is electromagnetic radiation (EM), but not all EM radiation is light. EM radiation is characterised by its wavelength, and visible is the range from just below 400 nm to just above 700 nm wavelength. In the near infrared range, green vegetation has about six times

higher reflectance than in the visible spectral range because the fresh leaf tissue has good reflectance for IR rays and the other wavelengths are absorbed by the chlorophyll and accompanying carotenoids.

Without a doubt, one of the most interesting developments of World War 2 were the infrared devices, which were then called ultra-red devices. By shifting the battle into the night, it was hoped to make up for the material inferiority of the German army. Before the discovery of German developments in this field, the USA had tried without success to convert infrared into visible light. Not only had the Germans managed to do this, but they had already successfully used infrared devices for military purposes.

Infrared detectors are devices that react to infrared light. Infrared waves cannot be seen with the human eye. The eye can see a basic spectrum of color - everything that can be seen in a rainbow of color. However, there are colors that range outside of a rainbow in the electromagnetic spectrum. Humans are called "trichromats," meaning that we can see red, green, and blue and everything in between. Technically interesting is also the possibility to penetrate light haze (fog) with IR devices. When it snows, however, the IR rays are reflected by the snowflakes and IR devices cannot be used. After the end of the war, the Allies captured the German inventions in this field and used them to build their "own" infrared devices. The devices were also used, for example, in the Korean War and the Indochina War.

Infrared science has played a revolutionary role in the development of the modern technology age. The infrared range of the electromagnetic spectrum spans from approximately 0.75  $\mu\text{m}$  to 1000  $\mu\text{m}$  [1,2]. The discovery of infrared radiation is credited to the British Royal Astronomer, Sir William Herschel who demonstrated this radiation in 1800 by using sunlight dispersed through a prism and detecting it with a sensitive thermometer [3]. This work laid the foundation of the field of infrared spectroscopy. For more than forty years, the enormous potential of this new form of radiation was not realized until the intervention of more sensitive detectors such as the radiation thermocouple and the diffraction grating spectrometer. Since then, there has been phenomenal progress in both basic and applied research in infrared science and technology [4]. Infrared spectroscopy has played a leading role in the achievement of this progress.

The article analyzes the evolution of HgCdTe infrared detectors, which have been intensively developed in the last forty years, as well as future trends in this field.

## 2. The evolution of manufacturing technology

Studies of the mechanical properties of CdZnTe and HgCdTe materials and the impact of plastic deformation on the electrical performance of infrared photodiodes have been published [5,6]. The works carried out has allowed the determination of the mechanical properties of  $\text{Cd}_{1-y}\text{Zn}_y\text{Te}$  and  $\text{Hg}_{1-x}\text{Cd}_x\text{Te}$  materials. The modulus of elasticity and hardness are lower than those of elemental semiconductors such as Germanium and Silicon. The fracture toughness, cracking threshold and toughness of these two materials were examined in detail as a function of the compositions,  $x$  and  $y$ , in ranges used for the design of infrared detectors. Nano- and micro-indentation methods were used to determine these mechanical data at room temperature [7].

As HgCdTe and CdZnTe materials are used at cryogenic temperatures, a micro-indentation tool was developed at liquid nitrogen temperature. These measurements determined an increase in the hardness, cracking threshold and toughness of HgCdTe and CdZnTe. Indentation generates plastic deformation marked by the presence of a footprint and

dislocations that are revealed by chemical etching [8,9]. The study of these dislocations was part of a second part of the study on understanding the nature of these dislocations and their electrical impact on the photodiodes.

The development of the indentation method as a tool for localised injection of dislocations into photodiodes was addressed. Tools such as chemical dislocation revelation and scanning and transmission electron imaging have revealed the presence of these dislocations with particular orientations dictated by the crystal structure of HgCdTe and CdZnTe materials [10]. A comparison was made between the nature of the injected dislocations and those present natively in the bulk materials, as well as their electro-optical impacts.

The third part of the study was the study of the electrical properties of HgCdTe-based infrared photodiodes [11,12]. These photodiodes are designed as arrays in order to produce high performance infrared images and videos [13-15]. However, sometimes pixels are missing from the image. The presumed origin was the presence of dislocations. This work has verified this hypothesis [16]. Using the micro-indentation technique, dislocations were injected into the photodiodes. Electrical measurements of current versus voltage and current versus time at fixed bias showed degradation caused by the presence of dislocations in the diodes. This degradation is mainly characterised by excess noise [17].

For comparison, HgCdTe materials have also been grown on GaAs and CdZnTe substrates (Figure 1). In the case of GaAs substrates, due to higher lattice mismatch than GaSb, a low temperature ZnTe nucleation technique was introduced to prevent twin generation (Figure 1c). A non-optimized HgCdTe/CdTe/GaAs structure was also grown for comparison (Figure 1b).

HgCdTe	HgCdTe	HgCdTe	HgCdTe
CdTe	CdTe	CdTe	CdTe
GaSb	GaAs	ZnTe	CdZnTe
		GaAs	
a)	b)	c)	d)

**Figure 1.** Growth structure for different substrates: *a)* GaSb substrate with 5  $\mu\text{m}$  buffer layer; *b)* GaAs substrate with the same structure of GaSb for compare; *c)* GaAs substrate with nucleation technology and 5  $\mu\text{m}$  buffer; *d)* CdZnTe substrate with 50 nm thin buffer layer [17].

Moreover, any kind of anneal process of HgCdTe involved in junction formation is associated with an impurity redistribution process and a change in Hg vacancy content. The formation of photovoltaic junctions in  $Hg_{1-x}Cd_xTe$  is still an open research task [18]. Today, the best results for research and production, and the best products quality, are obtained with molecular beam epitaxy (MBE) – for the great majority – and less with liquid phase epitaxy (LPE) (Figures 2 and 3).

### 3. CEA-Leti (Laboratory of Electronics and Information Technologies)

Research and development is necessary for the technology company to provide the innovation needed to succeed in its markets.

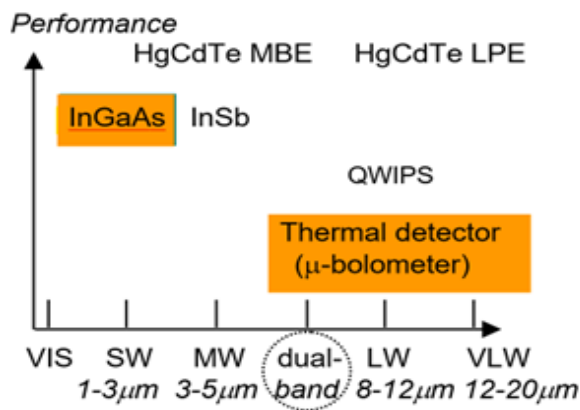

**Figure 2.** HgCdTe detectors grown by MBE and LPE deliver better object identification capability than thermal detectors, such as  $\mu$ -bolometers and those based on InGaAs and InSb [13].

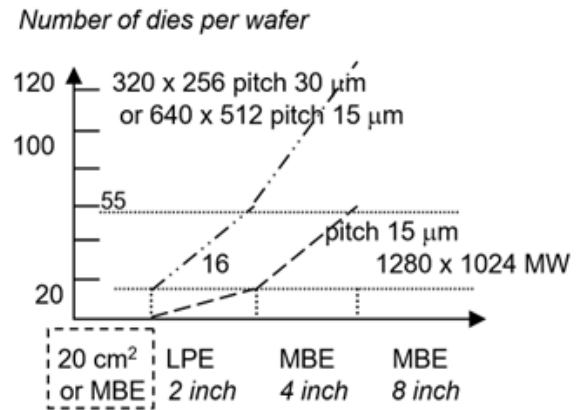

**Figure 3.** Switching from CdZnTe substrates to those made from Ge can substantially boost the number of dies per wafer [26].

The choice to collaborate with a partner can become crucial to achieve the expected growth. *Leti* brings together 2,000 people who are passionate about innovation in the service of industry. Experienced researchers, applications engineers, business managers, administrative support, a large majority of them have business experience [19-22]. A hundred or so scientific experts are internationally recognised and are members of learned societies. Around 400 PhD students and post-doctoral fellows bring the resourcefulness of youth every year [23-25].

Over the years, *Leti* has invested heavily in laboratory and manufacturing facilities that place it among the world's leading research institutes. In addition to high-tech microelectronics clean rooms, *Leti's* facilities include advanced characterisation tools that are often unique in the world, state-of-the-art test benches and unparalleled pre-clinical and clinical research platforms [26-28].

The essence of *Leti's* business model is its intellectual property policy and the objective of systematically protecting all new discoveries with a patent [29]. *Leti* relies on dedicated in-house resources and a renowned network of experts in the field to intelligently manage one of the world's largest patent portfolios [30-33]. This is a necessary and imperative cost, in order to offer future partners a competitive advantage and full protection in their markets.

Along with the patent policy, the other pillar of the business model is *Leti's* willingness to collaborate as closely as possible with its partners' strategies and needs. *Leti* is committed to building a tailor-made research programme, on an exclusive bilateral basis, adapted to the roadmaps and resources proposed. *Leti's* objective is to enable its customers to rapidly industrialize and bring to market the innovations it develops [34].

No research institute, however well endowed, can prosper without a network of related networks. Universities, engineering schools, other institutes, investors, companies... in France, Europe and abroad, *Leti* has patiently woven close relationships with a galaxy of players that it makes available to its partners in order to help innovations grow in an ecosystem that is conducive to their development.

*Leti* is a recognised player on the European scene and maintains close ties with its institutions. It is one of the institutes that receives the most funding from the for large-scale

research programmes. It is a sought-after partner in the constitution of consortia, with a success rate of projects submitted of over 30% [35-39]. *Leti* is one of the spearheads in terms of ambitious partnerships between Europe and Asia (Japan, South Korea, Taiwan).

#### 4. Future tendencies

Pixel sizes of the order of 10  $\mu\text{m}$  have been proven in hybrid systems. However, the practice of reducing pixel sizes may continue in future.

Reducing pixel size is essential for SWaP and cost reduction since the diameter of the optics goes down, and the size and weight of the dewar follow suit, and cooler power falls, but its lifetime and reliability improve. The pitch of 15  $\mu\text{m}$  is in production today at Sofradir (France) and pitches of 10  $\mu\text{m}$  and less are expected within a few years. There is a similar tendency to reduce the pixel size of microbolometer arrays to achieve several potential benefits.

Multispectral IR provides target identification under conditions where one wavelength is unable to identify the target. Multispectral colour display helps in object recognition. Four colours may be maximum number of bands that can be stacked in a single pixel. However, future trends and demands necessitate attempting almost all combinations of bands in short wave (SW), mid wave (MW) and long wave (LW).

#### 5. Conclusions

It may be predicted that HOT  $HgCdTe$  technology will remain in the game because of its established fabrication houses and favorable and tunable properties. Since its spectral wavelengths can be tuned, this material will have its presence in almost all the spectral bands from short to very long wavelength bands. The technology will also keep on reducing the pitch of the detector arrays. In this context, uncooled microbolometers are being developed down to 5 to 10  $\mu\text{m}$  pitch in LWIR. For achieving more integration times, for the same pixel area, signal or well capacity per unit area are required to be improved by innovations in integrating capacitor designs or else in fabrication technological capabilities. The foundry houses which can provide low manufacturing costs will continue to exist because of huge demand. Application for next generation of IRFPAs will include manportable sensors, micro UAVs, ground/wall penetration, missile warning, missile seekers, multispectral Surveillance will keep the technology pushing to its limits.

#### References

1. Bubulac, L. O. Defects, Diffusion and Activation in Ion Implanted  $HgCdTe$ . *Journal of Crystal Growth* 1988, 86, pp. 723-734.
2. Bubulac, L. O.; Benson, J.; Jacobs, R.; Stoltz, A.J.; Jaime-Vasquez, M.; Almeida, L. A. The Distribution Tail of LWIR  $HgCdTe$  -on-Si FPAs: A Hypothetical Physical Mechanism. *Journal of Electronic Materials*, 2011, 40, pp. 280-288.
3. Destafanis, G. New Generations of Infrared Detectors Based on  $HgCdTe$ . *Comptes Rendus Physique* 2003, 4 (10), pp. 1109-1120;
4. Tissot, J.-L. La détection infrarouge avec les plans focaux non refroidis: état de l'art. *Comptes Rendus Physique* 2003, 4, (10), pp. 1083-1088.
5. Rogalski A.  $HgCdTe$  Infrared Detector Material: History, Status and Outlook. *Reports on Progress in Physics* 2005, 68 (10), 2267.
6. Rogalski, A. Infrared Detectors: Status and Trends. *Progress in Quantum Electronics* 2003, 27 (2-3), pp. 59-210.
7. R. Irwan, H. Huang, H.Y. Zheng, H. Wu. Mechanical properties and material removal characteristics of soft-brittle  $HgCdTe$  single crystals, *Materials Science and Engineering: A*, Volume 559, 2013, pp. 480-485.

8. Dumanski, L.; Virt, I.; Kuzma, M. P-N Junction Formation in HgCdTe by Laser Annealing Method. In: *Conf. European Material Research Society E-MRS 2005 Spring Meeting*, Strasbourg, May 31–June 3, 2005.
9. Harris, J. S. Jr., Sahai, R.; Waldrop, J. R.; Bubulac, L. O. 1.06 Micron High Sensitivity IR Photocathode”, *Rockwell International, Thousand Oaks, California Science Center*, Final report, 6 January–30 June 1975.
10. Singh, R.; Mittal, V. Mercury Cadmium Telluride Photoconductive Long Wave Infrared Linear Array Detectors. *Defence Science Journal* 2003, 53 (3), pp. 281–324.
11. Bercier, E. J., Dessus, L.; Manissadjian, A. State-of-the-Art of Mass Production: Challenges for Low-Cost and Application Benefits of High-Performances Small-Pitch IR Detectors. In: *Proc. of the Infrared Technology and Applications XXXIV SPIE Conf.*, Orlando, FL, 17 March 2008, 6940, 69400I.
12. Chorier, Ph.; Vuillermet, M. Sofradir Infrared Detectors for Space Applications. *Proc. SPIE*, 2005, 5978, 597817. DOI:10.1117/12.627498.
13. Chorier, Ph.; Tribolet, Ph. High Performance HgCdTe SWIR Detectors for Hyperspectral Instruments”, [http://www.sofradir.com/\\_pdf/high\\_performance%20\\_hgcdcde\\_swir\\_detectors\\_for\\_hyperspectral\\_instruments.pdf](http://www.sofradir.com/_pdf/high_performance%20_hgcdcde_swir_detectors_for_hyperspectral_instruments.pdf)
14. Tribolet, Ph.; Vuillermet, M. IR Detectors Design and Approach for Tactical Applications with High Reliability without Maintenance. In: *Proc. of the Infrared Technology and Applications XXXIV SPIE*, Orlando, FL, USA, 17 March 2008, Vol. 6940, 69400H.
15. Veprik, A., Vilenchik, H.; Riabzev, S.; Pundak, N. Microminiature Linear Split Stirling Cryogenic Cooler for Portable Infrared Imagers. In: *Proc. of the Infrared Technology and Applications XXXIII SPIE*, Orlando, FL, 15 April 2007, Vol. 6542, 65422F.
16. Rutkowski, J. Planar Junction Formation in HgCdTe Infrared Detectors. *Opto-Electronics Review* 2004, 12 (1), pp. 123–128.
17. Yamamoto, K.; Somata, W.; Ikeda K. Design-for-Reliability Activity for Compound-Filled Leadless-Chip-Carrier-Packaged Charge-Coupled Devices. *Sanyo Tech. Review*, 2000, 32 (1), pp. 101–107.
18. Mynbaev, K.D., Ivanov-Omskii, V.I. Modification of  $\text{Hg}_{1-x}\text{Cd}_x\text{Te}$  properties by low-energy ions. *Semiconductors* 37, 1127–1150 (2003). <https://doi.org/10.1134/1.1619507>
19. Brzokoupil, V. Utilization of Noise Characteristic for Quality Check Of Solar Cells, [http://www.feec.vutbr.cz/EEICT/2004/sbornik/03-Doktorske\\_projekty/06-Mikroelektronika\\_a\\_technologie/03-xbrzok00.pdf](http://www.feec.vutbr.cz/EEICT/2004/sbornik/03-Doktorske_projekty/06-Mikroelektronika_a_technologie/03-xbrzok00.pdf)
20. Pucker, G, Bellutti, P.; Pavesi, L. Photoluminescence from  $(\text{Si}/\text{SiO}_2)_n$  Superlattices and Their Use as Emitters in  $[\text{SiO}_2/\text{Si}]_n \text{SiO}_2$   $[\text{Si}/\text{SiO}_2]_m$  Microcavities. *Spectrochim Acta A Mol Biomol Spectrosc.* 2001, 57(10), pp. 2019–2028.
21. Giraud, B.; Vaillant, L. CCD Reliability and Failure Mechanisms Study. In: *Proceedings of the Third ESA Electronic Components Conference*, ESTEC, Noordwijk, The Netherlands, 22–25 Apr. 1997, pp. 269–274.
22. Nagayama, I. Reliability Estimation of Electric Parts by Using CCD Camera and Neural Network. *Transactions of the Japan Society of Mechanical Engineers, C* 1999, 65 (634), pp. 2421–2427.
23. Theuwissen, A. J. P. Influence of Terrestrial Cosmic Rays on the Reliability of CCD Image Sensors. *IEEE Transactions on Electron Devices* 2007, 54 (12), pp. 3260–3266.
24. Eastman Kodak Company Image Sensor Solutions Quality Assurance and Reliability. <http://www.kodak.com/ezipres/business/ccd/global/plugins/acrobat/en/supportdocs/qualityAssuranceReliability.pdf>. 33<sup>rd</sup> IEEE Photovoltaic Specialists Conference (PVSC), San Diego, CA, May 11–16, 2008.
25. Zippel, C. L. Competing Processes in Long-Term Accelerated Ageing of Double Heterostructure GaAlAs Light Emitting Diodes *J. Appl. Phys.* 1982, 53, pp. 1781–1786.
26. Riley, K. J. LWIR HgCdTe Photovoltaic Detectors for Hybrid Focal Plane Arrays. *International Electron Devices Meeting* 2005, 26, pp. 490, 2005–08–09.
27. Tribolet, Ph. HgCdTe Technology in France. *Comptes Rendus Physique* 2003, 4(10), pp. 1121–1131.
28. Norton, P. HgCdTe Infrared Detectors. *Opto-Electronics Review* 2002, 10(3), pp.159–174.
29. Research and Markets Brochure, 2008, “Perspectives on the Optoelectronics Industry”, <http://www.researchandmarkets.com/reports/595701/>
30. Haldvordsson, E. Automotive Grade Gate Drive Optocoupler for HEVs. *Power Electronics Europe*, 2008, 6, pp. 26–27.
31. Brzokoupil, V. Utilization of Noise Characteristic for Quality Check Of Solar Cells, [http://www.feec.vutbr.cz/EEICT/2004/sbornik/03-Doktorske\\_projekty/06-Mikroelektronika\\_a\\_technologie /03-xbrzok00.pdf](http://www.feec.vutbr.cz/EEICT/2004/sbornik/03-Doktorske_projekty/06-Mikroelektronika_a_technologie /03-xbrzok00.pdf)
32. McMahon, T. J. Solar Cell / Module Degradation and Failure Diagnostics. In: *Proceedings of the 46<sup>th</sup> IEEE Annual International Reliability Physics Symposium*, Phoenix, 2008, pp. 172–177.

33. Uddin, M. A.; Chan, H. P. The Challenges in the Fabrication of Reliable Polymer Photonic Devices”, *Journal of Material Sciences: Materials in Electronics* 2009, 20, pp. 277-281.
34. Breeze, A. J. Next Generation Thin-Film Solar Cells. In: *Proceedings of the 46<sup>th</sup> IEEE Annual International Reliability Physics Symposium*, Phoenix, 2008, pp. 168-171.
35. Băjenescu, T. I.; Băzu, M. *Reliability of Electronic Components. A Practical Guide to Electronic Systems Manufacturing*, Berlin and New York: Springer, 1999.
36. Băjenescu T.-M., *Zuverlässige Bauelemente für elektronische Systeme*, Berlin and New York, Springer, 2020.
37. Băjenescu T.-M.; Băzu, M. *Component Reliability for Electronic Systems*, Artech House, Norwood, MA, 2010.
38. Capper, P.; Garland, J. (eds.) *Mercury Cadmium Telluride Growth, Properties and Applications*. Wiley, 2011.
39. Băjenescu T.-M. Infrared detectors. *Journal of Engineering Science*, 2018, 25(3), pp. 29 – 40.

**Citation:** Băjenescu, T.-M. A material full of promises:  $Hg_{1-x}Cd_xTe$  - mercury cadmium telluride. *Journal of Engineering Science* 2023, 30(1), pp. 99-105. [https://doi.org/10.52326/jes.utm.2023.30\(1\).08](https://doi.org/10.52326/jes.utm.2023.30(1).08).

**Publisher’s Note:** JES stays neutral with regard to jurisdictional claims in published maps and institutional affiliations.



**Copyright:**© 2023 by the authors. Submitted for possible open access publication under the terms and conditions of the Creative Commons Attribution (CC BY) license (<https://creativecommons.org/licenses/by/4.0/>).

**Submission of manuscripts:**

[jes@meridian.utm.md](mailto:jes@meridian.utm.md)