

## THE HANDHELD DEVICE FOR STUDYING SKIN REACTION TO LIGHT

A. V. Pocropivnii\*, V. S. Verbitskii

*Department of Microelectronics and Biomedical Engineering, Technical University of Moldova,  
Chisinau, Republic of Moldova*

\*E-mail: [pocropivni.anatol@gmail.com](mailto:pocropivni.anatol@gmail.com)

The portable, handheld device was developed to study the body reaction to skin illumination with light. It can be used in such applications as speed of regeneration and healing, also for testing efficiency of this kind of treatments. The block diagram is shown in Figure 1.

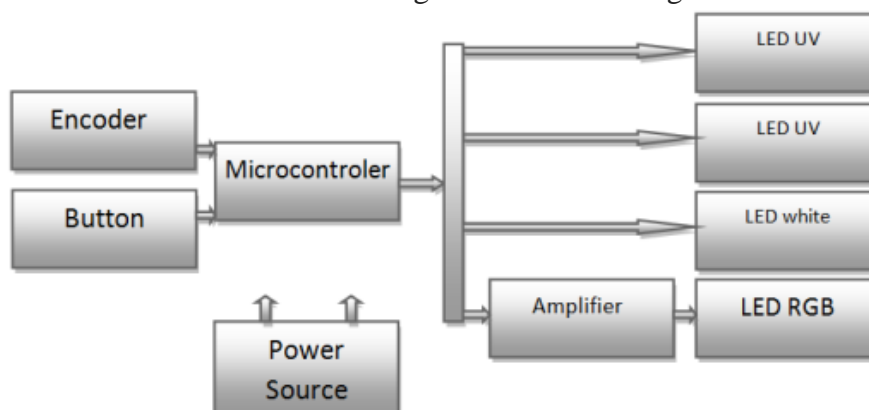

**Figure 1** Block diagram of the device

It features three light sources: an UV source with a wave length of 390 nm, and another UV source with wave length of 402 nm, a white LED and RGB LED . The user can choose the desired source and light intensity. RGB LED can be set to the desired lighting, user can independently adjust each color for red, green and blue. Photo of the device is shown below(Fig.2).



**Figure 2.** Device for studying skin reaction to light

**Acknowledgements.** This work was partially supported by the STCU within the Grant 5989.

- [1] V. Cretu, V. Postica, A.K. Mishra, M. Hoppe, I. Tiginyanu, Y.K. Mishra, L. Chow, N.H. de Leeuw, R. Adelung, O. Lupan, J. Mater. Chem. A. **volume 4** (2016) 6527-6539.