

Topology and Circuit Analysis of Photovoltaic Module Integrated Inverters

Vladimir GOREMICHIN

Institute of Applied Physics of the Academy of Sciences of Moldova

vgoremichin@phys.asm.md

Abstract — Special requirements on the system structure, components selection and converter topology of the Module Integrated Inverters (Converters) for PV applications are considered. Under discussion are the features of usage of different converter topologies in photovoltaics, including buck, boost, forward, flyback converters. Examples are studied of using Silicon Carbide junction field-effect transistors in PV inverters and their influence on the inverter schematics. The single-stage Module Integrated Inverter (Solar Microinverter SMI-01) has been designed and fabricated in the frame of this work. The developed microinverter uses the interleaved flyback topology and is intended for integration in PV modules up to 240W. It has the following parameters: input voltage - $30 \div 48V$, maximum system voltage - 600V, efficiency - 96%, output current THD - 4.5%, input/output isolation, dimensions - 220 x 150 x 56 mm. Microinverter is traced on the 4-layer PCB and placed in the IP65 case.

Index Terms: module integrated inverter, photovoltaics, solar microinverter.

Characteristics of photovoltaic (PV) inverters (converters) play an important role in the PV system performance and influence such system parameters as efficiency, life time, quality of the output mains voltage, etc. The Module Integrated Converter (MIC) concept (also called PV AC module) is a further step on the way of the system integration and is associated with a DC-AC inverter embedded into each PV module [1]. Fig.1 illustrates the Module Integrated Converter concept.

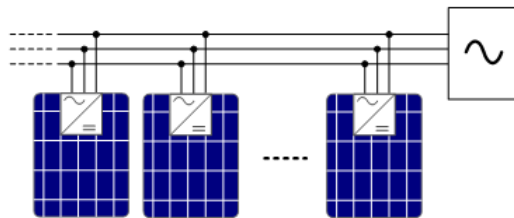

Fig.1a. Connection of MIC in parallel to the grid [1]

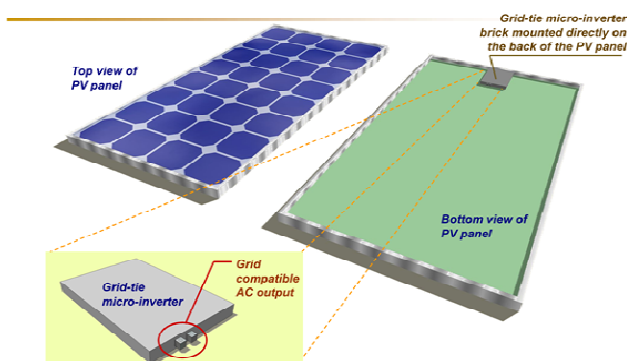

Fig.1b. Module Integrated Converter concept [1]

On the system level, the MIC concept offers several unique features, such as:

- Individual Maximum Power Point Tracking (MPPT)
- Optimal energy harness from each panel
- No single-point failure

- No mismatch losses
- No DC-specific equipment
- Lower acquisition & installation costs [1].

Inverters integrated with the PV module are supposed to operate under harsh conditions (temperature stress, humidity, cycling, high lighting, etc.) for a long time. This imposes special requirements on the critical factors such as the system structure, components selection, converter topology and thermal control.

When selecting an appropriate converter topology, it is necessary to take into account the following factors:

- Number of outputs
- Necessity of input to output dielectric isolation
- Level of the output voltage with respect to the whole range of the input voltage
- Maximum voltage applied across the transformer primary
- Maximum duty cycle, etc.

Depending on the abovementioned factors one of possible converter topologies could be selected: buck, boost, forward, flyback, half-bridge, full-bridge and so on.

In a **buck converter**, a switch is placed in series with the input voltage source and it can produce only a lower average output voltage than the input voltage. The input source feeds the output through the switch and a low-pass filter implemented with an inductor and a capacitor [2]. In a buck converter, its input current is always discontinuous; this results in a larger electromagnetic interference (EMI) filter than with other topologies.

In a **boost converter**, an inductor is placed in series with the input voltage source. A boost converter can produce only a higher output average voltage than the input voltage. The input source feeds the output through the inductor and the diode or transistor. The boost converter is an ideal choice for the Power Factor Correction (PFC) application. The Power Factor (PF) is given as the product of the Total Current Harmonics Distortion Factor (THD) and the Displacement Factor (DF) [2].

A **forward converter** is a transformer-isolated converter based on the basic buck converter topology. In a forward converter, a switch is connected in series with the transformer. The switch creates a pulsating voltage at the transformer primary winding. The transformer is used to step down the primary voltage and provide isolation between the input voltage source and the output voltage [3]. The efficiency of a forward converter is low compared to that of other topologies with the same output power, due to the presence of four major loss elements: the switch, transformer, output diode rectifiers, and output inductor. In order to decrease the maximum voltage stress of the switch in a forward converter, the two-switch forward converter topology can be used, by placing one more switch in series with the transformer primary winding. The two-switch forward converter is best suited for applications with an output power level range of 200 to 350 watts.

A **flyback converter** is a transformer-isolated converter based on the basic buck boost topology. In a flyback converter, a switch is connected in series with the transformer. The transformer is used to store the energy during the ON period of the switch and provides isolation between the input voltage source and the output voltage. At the end of the T_{ON} period, when the switch is turned OFF, the transformer magnetizing current continues to flow in the same direction. The magnetizing current induces a negative voltage in the dot end of the transformer winding with respect to the non-dot end [3].

The energy stored in the primary of the flyback transformer is transferred to the secondary through the flyback action. This stored energy provides energy to the load, and charges the output capacitor. Flyback topology is widely used for the output power from 5 to 150 watt of a low-cost power supply. The flyback topology does not use an output inductor, thus saving cost and volume as well as losses inside the flyback converter. The absence of both the output inductor and the freewheeling diode makes the flyback converter topology best suited for high output voltage applications. If the output current requirement is over 12-15 amps, the RMS peak-to-peak ripple current seen by the output capacitor is very large, and it becomes impractical to handle. So, it is better to use the forward converter topology than the flyback topology for an application where the output current requirement is high.

In order to provide operation of the inverter embedded in the PV module under harsh conditions, the components selection approach should mean:

- avoid using temperature sensitive components such as optoelectronic devices
- improve operating conditions for electrolytic capacitors thus aiming to achieve long useful life
- use highly efficient electronic components. High efficiency is not only a price point, but also improved reliability of inverters as the thermal stress is reduced.

A promising concept in the area of electronic components for inverters is using Silicon Carbide (SiC) junction field-effect transistor (JFET) device [4, 5]. The SiC material is characterized by the electrical field strength almost 9 times higher than normal Si, that allows to design semiconductor devices with very thin drift layers and, as a consequence, low on-state resistance and reduced switching losses.

Normally-on SiC JFET device with a monolithically integrated body diode combines ultra-fast switching with ohmic-forward characteristic and a zero reverse recovery characteristic of its body diode [4]. SiC JFET can be operated at a high voltage and higher switching frequencies without significant prejudice on the efficiency, which leads to a possibility to reduce the size of passive components and, consequently, the cost and volume of the circuit. However, since their characteristics are quite different from those of conventional semiconductors, new design strategies are required. The normally-on characteristic of JFETs promotes its usage in PWM Current Source Inverters. The typical scheme of such inverter, using only one high frequency (HF) switch S1 on the base of normally-on SiC JFET device, is shown in Fig.2 [6].

Fig.2. Single HF-switch Indirect Current Source Inverter

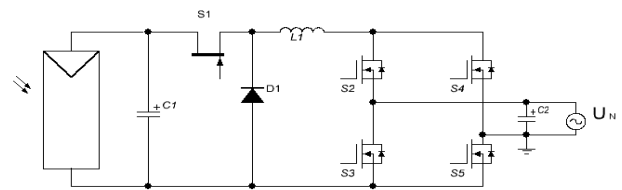

Advantages of a single HF-switch Indirect Current Source Inverter are the following:

- There is always a path for the DC-link inductor current
- Voltage can be boosted
- HF common mode leakage current is minimized.

Due to its simplicity this topology is often used in small power PV applications.

Another example of a normally-on SiC JFET usage is presented in Fig.3.

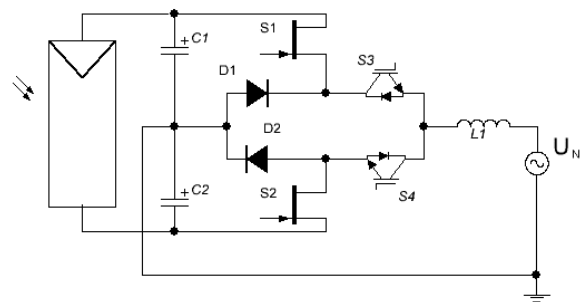

Fig.3. Neutral-point clamped inverter with JFET/IGBT [6]

It is the well-known voltage source 3-level Neutral-point clamped (NPC) inverter with incorporated normally-on switches (S1/S2), so each branch consists of an indirect series connection of two switches and an external freewheeling diode [6]. Since no switch losses occur in S3/S4, slow normally off switches are used which make the circuit inherently safe. The NPC inverter is a very suitable topology for PV, especially for 3-phase applications.

Taking into account the abovementioned features of converter topologies, a low power cost-effective solar single-phase module integrated inverter SMI-01 has been designed and fabricated.

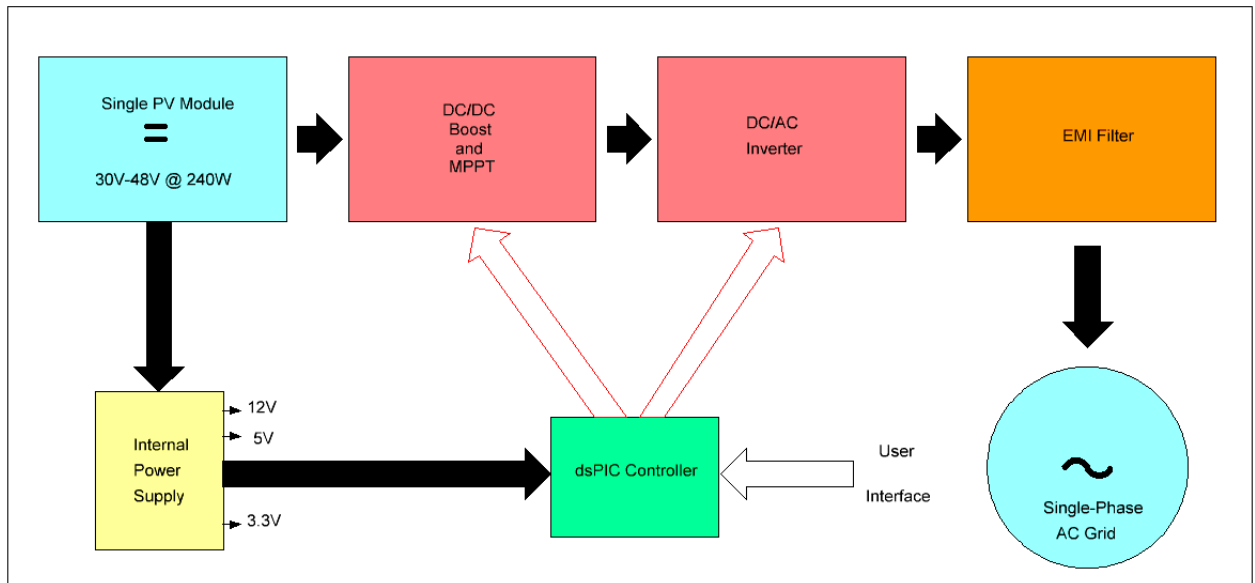

Fig.4. Module Integrated Inverter block diagram

The block diagram of the proposed Module Integrated Inverter is shown in Fig.4. In order to make the system simpler, of a high efficiency and reduced cost, the single-stage topology is used. The DC/DC converter boosts the low voltage of the PV panel (30÷48V) up to 600V with the input/output isolation. The simple boost topology have been used in this block. The DC/AC inverter (together with the filter) produces the sinusoidal output voltage and current synchronized with the grid voltage. An Electromagnetic Interference (EMI) filter is used to suppress the EMI noise and provide impedance between the inverter output and the grid.

The overall system control is performed by the dsPIC33F (Microchip Technology Inc.) – 16-bit Digital Signal Controller (DSC). The DSC handles all system blocks, carries out the MPPT algorithm, fault control, as well as certain optional digital communication routines. The PV panel voltage is the source of the internal power supply, to the controller and the feed-back circuitry. SMI-01 Module Integrated Inverter uses the interleaved flyback topology and contains two flyback converters, coupled in parallel,

that are 180° out of phase with respect to each other. The interleaved flyback converter block diagram is shown in Fig.5. The DC input from the PV module is fed to the flyback primary. A high-frequency Pulse Width Modulator is used to control the flyback MOSFETs and diodes to generate the rectified output voltage across the flyback output capacitors.

At the input side, the total input current drawn from the PV panel equals the sum of the two flyback MOSFET currents. Because the ripple currents through the two flyback transformers/MOSFETs are out of phase, they cancel each other and reduce the total ripple current in the input side. At a duty cycle of 50%, the best cancellation of ripple currents is possible. So, interleaved flyback topology allows decreasing the ripple current through the input electrolytic capacitors, the magnetic core dimensions and the output current total harmonic distortion (THD). Circuitry of interleaved flyback converter is shown in Fig.6.

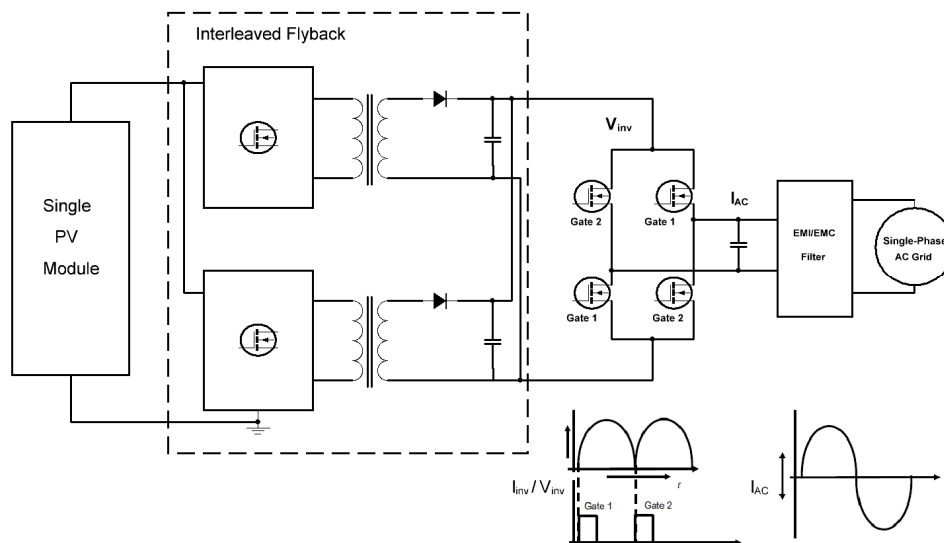

Fig.5. Interleaved flyback converter block diagram

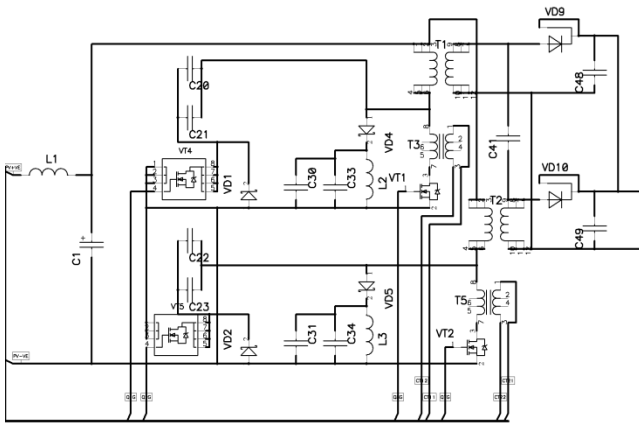

Fig.6. Fragment of Circuitry of interleaved flyback converter

The control system of the developed inverter includes several control loops: the MPPT Loop, the Digital Phase-Locked Loop (PLL), and the Current Control Loop. The reference design uses the P&O method for the MPPT [7]. The MPP tracker operates by periodically incrementing or decrementing the solar array voltage. If a given perturbation leads to an increase (decrease) of the output power of the PV, the subsequent perturbation is generated in the same (opposite) direction.

The PLL generates the grid voltage's frequency and phase angle for the control to synchronize the output to the grid. The SMI-01 micro inverter is shown in Fig.7.

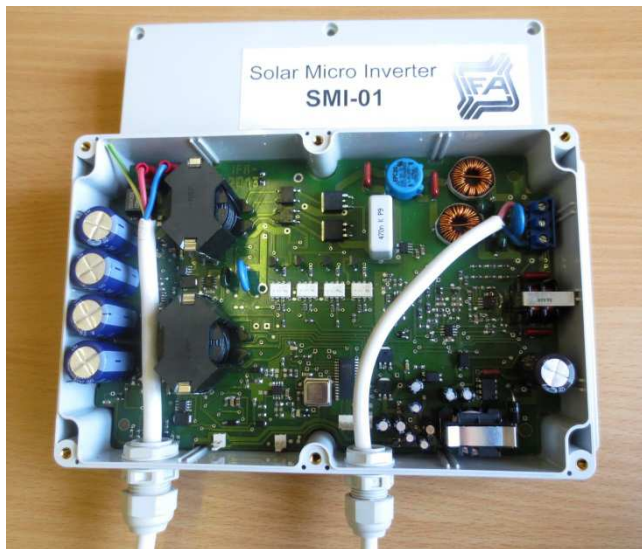

Fig.7. Photo of SMI-01 solar micro inverter

Parameters of the module integrated inverter SMI-01 are presented in Table 1. The developed microinverter is intended for integration in PV modules up to 240W. It is traced on the 4-layer PCB and placed in the IP65 case.

TABLE 1. PARAMETERS OF SMI-01 INVERTER

Name	Value
Input voltage, V	30 ÷ 48
Output voltage, V	220
Rated power (PV module), W	240
Max System voltage, V	600
Efficiency, %	96
Output current THD, %	4.5
Control	Full digital
Case	IP65
Dimensions, mm	220 x 150 x 56
Operative temperature, °C	-30 ÷ +70

CONCLUSION

PV applications impose some constraints and requirements on the system structure, components selection, inverter (converter) topology. The boost converter is an ideal choice for the PFC application. The two-switch forward converter is best suited for applications with an output power range of 200 to 350 watts. The flyback topology is the best solution for low-power cost reduced PV inverters. Using of the high-performance component, such as normally-on SiC JFET devices, in PV inverters, leads to a higher efficiency but requires special schematic solutions. The single-stage Solar Micro Inverter SMI-01 has been designed and fabricated. The developed microinverter uses the interleaved flyback topology and is intended for integration in PV modules up to 240W.

REFERENCES

- [1] J. Liu, N. Henze, Reliability consideration of Low-Power Grid-Tied Inverter for photovoltaic application, EU PVSEC Proceedings, pp.3688 - 3694, 2009.
- [2] M. Kamil, Switch Mode Power Supply (SMPS) Topologies (Part 1) AN1114 Microchip Technology, pp. 6-7, 2007.
- [3] B. Shaffer, Interleaving Contributes Unique Benefits to Forward and Flyback Converters, TI, 2005, <http://www.ti.com/lit/ml/slup231/slup231.pdf>
- [4] New SiC JFET Boost Performance of Solar Inverters, Solar Power, Power Electronics Europe, vol.4, pp.29-33, 2009.
- [5] H. Zang, L. M. Tolbert, Efficiency of SiC JFET-Based Inverters, IEEE ICIEA 2009, pp.2056-2059, 2009.
- [6] B. Sahan et.al., Photovoltaic converter topologies suitable for SiC-JFETs, Proceedings PCIM Europe Conference, pp.431-437, 2009.
- [7] S. Esther Glory, P.S. Dhivya, T. Sivaprakasam, Solar Powered High Efficient Converter for Battery Charging, IJIREEICE, vol.1, pp. 448-452, 2013.